

MADLEN *NITSCH*  
PORTFOLIO

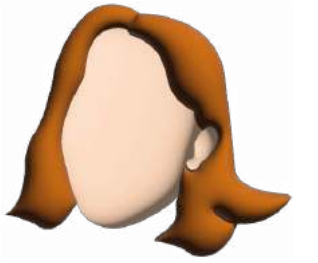

- 01 AUCH SELBER *DENKEN*
- 02 PRETTY *UGLY*
- 03 ENCOUNTERINGS
- 04 DELIQUESCE *EYES*
- 05 LE TEMPS *PASSE*
- 06 GOING IN *CONTOURS*
- 07 PEACE IN *CHAOS*
- 08 ON THE *GO*
- 09 EMOTIONAL *EYES*
- 10 THE DISASSEMBLED *MOUSE*
- 11 MUSIC IN *COLOURS*
- 12 ABOUT *ME*

# 01 AUCH SELBER DENKEN



To also think for yourself is the message of this poster series. For our final project in school we were free to choose what we would do. Since we live in this modern age where everybody has access to media and everybody can create media I decided to do a critical series on the topic of media consumption. A reminder to while consuming media – to also think for yourself and not let mainstream media form your entire opinion.

LECTURERS  
Rafael Koch  
Martin Woodtli



21. März 2023  
**Auch selber denken**  
Konstant konsumieren wir Informationen aus allen möglichen Richtungen. Oft ist einem gar nicht mehr durchgehend, unter anderem Informationen aufnimmt. In einigen Fällen das Meinungen, die von anderen stammen, bedeutet. Ununterbrochen sind wir also den besten Quellen

21. März 2023  
**Auch selber denken**  
Konstant konsumieren wir Informationen aus allen möglichen Richtungen. Oft ist einem gar nicht mehr durchgehend, unter anderem Informationen aufnimmt. In einigen Fällen das Meinungen, die von anderen stammen, bedeutet. Ununterbrochen sind wir also den besten Quellen

21. März 2023  
**Auch selber denken**  
Konstant konsumieren wir Informationen aus allen möglichen Richtungen. Oft ist einem gar nicht mehr durchgehend, unter anderem Informationen aufnimmt. In einigen Fällen das Meinungen, die von anderen stammen, bedeutet. Ununterbrochen sind wir also den besten Quellen

21. März 2023  
**Auch selber denken**  
Konstant konsumieren wir Informationen aus allen möglichen Richtungen. Oft ist einem gar nicht mehr durchgehend, unter anderem Informationen aufnimmt. In einigen Fällen das Meinungen, die von anderen stammen, bedeutet. Ununterbrochen sind wir also den besten Quellen

schöne  
buep Spoken  
Jazz  
von Martin Frank  
seit  
adjö

theater

Josefstrasse 106, 8005 Zürich  
www.sogaz.ch

**kunst zürich**  
www.kunstschi.ch

<b>Lutz Böh</b> Kunstwerk Wahr & Wirk	<b>Floris Grunewitz</b> Kunstwerk Wahr & Wirk	<b>Schaal Lager</b> Kunstwerk Wahr & Wirk
<b>Janet Olyson</b> Kunstwerk Wahr & Wirk	<b>Gabriela Berti</b> Kunstwerk Wahr & Wirk	<b>Carroll Dunham</b> Kunstwerk Wahr & Wirk
<b>Augustin Koberle</b> Kunstwerk Wahr & Wirk	<b>RESART</b> Kunstwerk Wahr & Wirk	<b>UNIVERSE OF A NOMAD</b> Kunstwerk Wahr & Wirk
<b>Winter Group Show</b> Kunstwerk Wahr & Wirk	<b>Jorge Mández Blake</b> Kunstwerk Wahr & Wirk	<b>Rend Kemp</b> Kunstwerk Wahr & Wirk

**BULLE**  
Suna Güler  
Uraufführung:  
21. Jan. 2022,  
Schiffbau  
**STRESS**  
Schauspielhaus  
Zürich



21. März 2023  
**Auch selber denken**  
Konstant konsumieren wir Informationen aus allen möglichen Richtungen.  
Off ist einem gar nicht mehr durchgehend, unter anderem in einigen Fällen die Meinungen, die von anderen stammen, bedeutet.  
Ununterbrochen sind wir also den besten Quellen

BALLET ZÜRICH  
MONTEVERDI

LIVE MULTIVISION + CORRADO FILIPPONI  
**WUNDERLAND SCHNEIZ**  
VIA ALPINA

SO ERLEBEN SIE  
DAS ERSTE  
KAMMER  
Die kann nur Musik  
25/01/22  
FESTKONZERT MIT DUDU  
IN MEMORIAM ALBERT  
19.30 UHR, TONHALLE  
Landesmusik  
27. Januar 2022  
Dschungel

Städtischer-Stein der Stadt Zürich



Welcome

Schw...

24

3' Wey

4' Kapuziner

10' Wesemlin-Unt

26



ich selber denken

März 2023

...umieren wir Informationen  
...den Richtungen.

Ort  
...der Zeitung am Bahn-  
...dem Handy, so  
...dem Aussehen



ESSB  
rossloh  
Electrical Systems



Neues Coronavirus  
SO SCHÜTZEN



NOTAUSGANG

Kin  
ohr





1. März 2023

# Auch selber denken

Konstant konsumieren wir Informationen aus allen möglichen Richtungen. Morgens die News in der Zeitung am Bahnhof. Später Nachrichten auf dem Handy. So wie Beiträge auf Instagram. Beim Autofahren das Radio und letztlich die Abendnews im Fernseher.

Wir sind im heutigen Alltag stets umgeben von Informationen aus zweiter und dritter Hand. Da würde es nicht schaden, etwas selbst zu denken. Wir leben in einer Welt, die bombardiert wird mit Informationen, die wir auf Medien angewiesen, wie würde man sonst an relevante Informationen bezüglich der Welt kommen und unsere menschliche Mitbestände stärken?

Oh ist einem gar nicht durchgehend unter an Informationen aufnimmt. In einigen Fällen das Meinungen, die von anderen stammen, bedeutet. Ununterbrochen sind wir also den verschiedensten Quellen ausgesetzt. Es ist dem sprechend sehr einfach, sich einer gelesenen Ansicht anzuschließen. Überzeugt zu werden, sich direkt selbst an diese Sicht zu Dinge anzuschließen. Gefährlicher ist es, sich zuerst eigene Gedanken über einen Beitrag zu bilden.



märz 2023

**ch selber denken**

sumieren wir Informationen  
nen Richtungen.

der Zeitung am Bahn-  
if dem Handy, so-  
im Auf

Off  
dur  
In





21. März 2023

## Auch selber denken

Konstant konsumieren wir Informationen aus allen möglichen Richtungen.

Morgens die News in der Zeitung am Bahnsteig, später Nachrichten auf dem Handy, schließlich die Abendnews auf Instagram. Beim Autofahren...

Off ist einem gar nicht mehr durchgehend, unter anderem Informationen aufnimmt. In einigen Fällen das Aussehen, die Meinungen, die von anderen stammen, bedeutet.

Ununterbrochen sind wir also den besten Quellen...



# 02 PRETTY *UGLY*



Is it pretty or ugly? This decision can only be made by the subjective observer — yourself. We humans can see the same thing visually, but our opinion on it can differ. Everyone has their own “glasses” with which they see the world. A person can see the same thing, nevertheless, perceive something completely different through different opinions and associated memories. “The Golden Spray Can” makes this idea clear. Spray-cans are considered ugly by society. But by gilding the spray can, which is otherwise regarded as ugly, our perception of it changes. Why is something as hideous as graffiti culture now being glorified and gilded? Or should this urban art form be valued after all? But who can determine that, apart from you for yourself?

LECTURERS  
Martin Woodtli  
Felix Pfäffli  
Martin Infanger





PROCESS

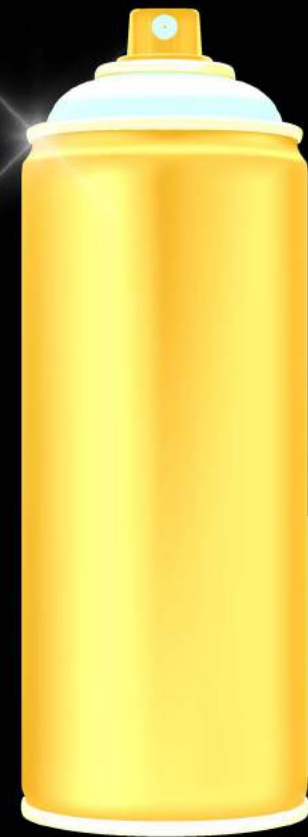



# 03 ENCOUNTERINGS



In this project the task was portraying the Andreas Züst Library. Thus, making the main topic books. Our class spent three days in Appenzell Switzerland, gathering material consisting of ten books, drawings of the covers and choosing one picture in each book. Using the material collected by our class comrades each person made a book. This task included turning many different, but nevertheless alike materials, into a unified book. In my book I created a concept using the pun Encounters. The viewer encounters the book itself. At the same time in the book encounters continuously take place in the interviews, formation of the pictures, texts encountering pictures and so forth. The layout of the images happens by optic similarities—the closer they are optically, the closer they are aligned. The constantly changing alignment of pictures and text will make you want to look through the entirety of the pages—here is a glimpse of my book.

LECTURERS  
Patrina Strähl  
Valeria Bonin  
Markus Wiedi  
Marco Backer  
Martin Infanger

ENCOUNTERINGS

but it's a fantasy book with fighting, magic and romance. It got recommended to me and I really enjoy reading it. However, I don't know if I would recommend it to you. I got the feeling girls would like it more than boys?

"Monsters" sound interesting too. I have never read a manga, only "Betty and Veronica" or "Donald Duck" comics when I was in primary school. Can you remember what you read in primary school? I hated reading, that is why I liked comics. How about you? Or did someone read books to you, when you were younger? Maybe "Harry Potter"?

Have a nice day!!!  
Valerie

08.40 a.m., 30 July 2021  
Sorry for not sending a reply letter back yet, I've been quite sick from my second Covid vaccine, but I'll send it soon.

10.41 a.m.  
No problem! I hope u are feeling better.

12.17 p.m., 02 August 2021  
Hi, I already wrote the letter, but I forgot to send it before we went on holiday to Italy, do you need to be done with it before holidays end cuz if you do I will just rewrite what I wrote to you by text. I will be back in 2 weeks and then I could send it if you don't need it before then. I am really sorry.

1.51 p.m.  
Hi Max! No problem, I have time till the 27th of August. But I have a question. The material I collect, like our letters, will be put into a pot

for everyone to use. This means if I scan our letters, everyone could use them for their own project. I wanted to ask if that is okay for you because letters are kind of personal. I would find it really cool if you were okay with me scanning them. But I would fully understand if you would not want that.

4.05 p.m.  
Hey Valerie, I don't mind if you scan the letters. Although I would like to see what actually turns out of them. I think it is pretty fun writing letters. You think much more about what you write.

4.15 p.m.  
Really happy to hear that! I will be very excited to show u the results as soon as they are done!

4.21 p.m.  
Can't really imagine what someone will make out of those letters, but I guess I'll see.

4.22 p.m.  
Hahahah well... I definitely want to find a way to use them... idk about the others, perhaps they will too, lol!

16 August 2021  
Hi Valerie  
I remember reading "Das magische Baumhaus" in primary school but I honestly can't remember much. I think it was about some time travelling tree house or so. I don't have a booklist that I keep but I do definitely have plenty of books I would like to read. Oh yeah, I also remember reading "Diary of a Wimpy Kid" in primary. It was probably my favourite back then. I will try to

think of some manga to recommend for the next letter. And yeah, you definitely have missed out by not reading "Harry Potter", but it's never too late. Also just cuz I am a guy doesn't mean I don't appreciate a good romance. I think I will make a proper booklist now.

Have a splendid day!  
Max

19 August 2021  
Hey Max, I actually remember reading "Das magische Baumhaus" too when we were in primary. Didn't we read it with Mrs. Stocker? But I can't remember the story either. However, I will probably never forget the "Diary of a Wimpy Kid" books. I loved them. I remember reading them on the couch. Do you have a favourite place for reading? Btw, what is your motivation for reading? I think I like fiction and fantasy so much because it is an escape from our everyday life and reality. Furthermore, I love to imagine stuff and daydream. Is there a book that has changed your view of yourself and of the world? Now it's getting deep, isn't it? But it's an obligatory question, sorry. I believe I do self-reflection while reading, especially when the book is written in the first-person point of view. Because I kind of compare myself to that character, but not in a negative way. I don't know how I should describe it. I hope you had wonderful holidays and I wish you a great week! Oh, and what have you read today? (except the letter of course) Yours sincerely, Valerie

24 August 2021  
Hi Valerie  
I've recently been reading most of my books (mainly manga) digitally because it's way cheaper and stops me from having to order them online. Swiss bookstores have a terrible manga selection. I mainly read in bed though. I would definitely say I mainly read for escapism. But the books I end up liking the most, are the ones that make me think. I like to not understand a story, and then interpret it myself and add my own meaning. If you know what I mean? There are definitely books that have changed my outlook on life and I don't know what it is, but Japanese books/writing style just resonates more with me. Hard to explain why but it could be the cool/crazy concepts. I recently read "Remake our Life". That is about a guy who lives a boring life and regrets not going to art school, who then gets to go back in time and relive his life to the fullest. It is mainly about the side characters though and the moral is you regret what you don't do. It's a fun story. I usually don't insert myself into stories though. Maybe it's just the type of books I read... Haven't read today but I read "Remake our Life" vol. 3 yesterday (it's a quick easy read).

Sayonara  
Max



Letter written between Max and Valerie

Hi Valerie  
I've recently been reading most of my books (mainly manga) digitally because it's way cheaper and stops me from having to order them online. Swiss bookstores have terrible manga selection. I mainly read in bed though. I would definitely also say ~~the~~ I mainly read for escapism but the books I end up liking the most are ones that make me think, I like not understanding a story and then interpreting it myself and adding my own meaning if you know what I mean. There is definitely books that have changed my outlook on life and I don't know what it is but Japanese books/writing style just resonates more with me. Hard to explain why but maybe it's just the cool/crazy concepts. I recently read "Remake our Life", that about a guy who lives a boring life and regrets not going to art school who then gets to go back in time and relive his life to the fullest. It's mainly about the side characters though and the moral is you regret what you don't do ~~more than~~ the most, so just do stuff even if your head tells you not to because it will be awkward or whatever excuse you come up with. It's a fun story. I usually don't insert myself into stories though. Maybe it's just the type of books I read. Haven't read today but I read "Remake our Life" vol. 3 yesterday (it's a quick easy read).  
Sayonara  
Max  
sorry for taking long, I'll make sure to send the rest one before the 27th if you have more questions have you!

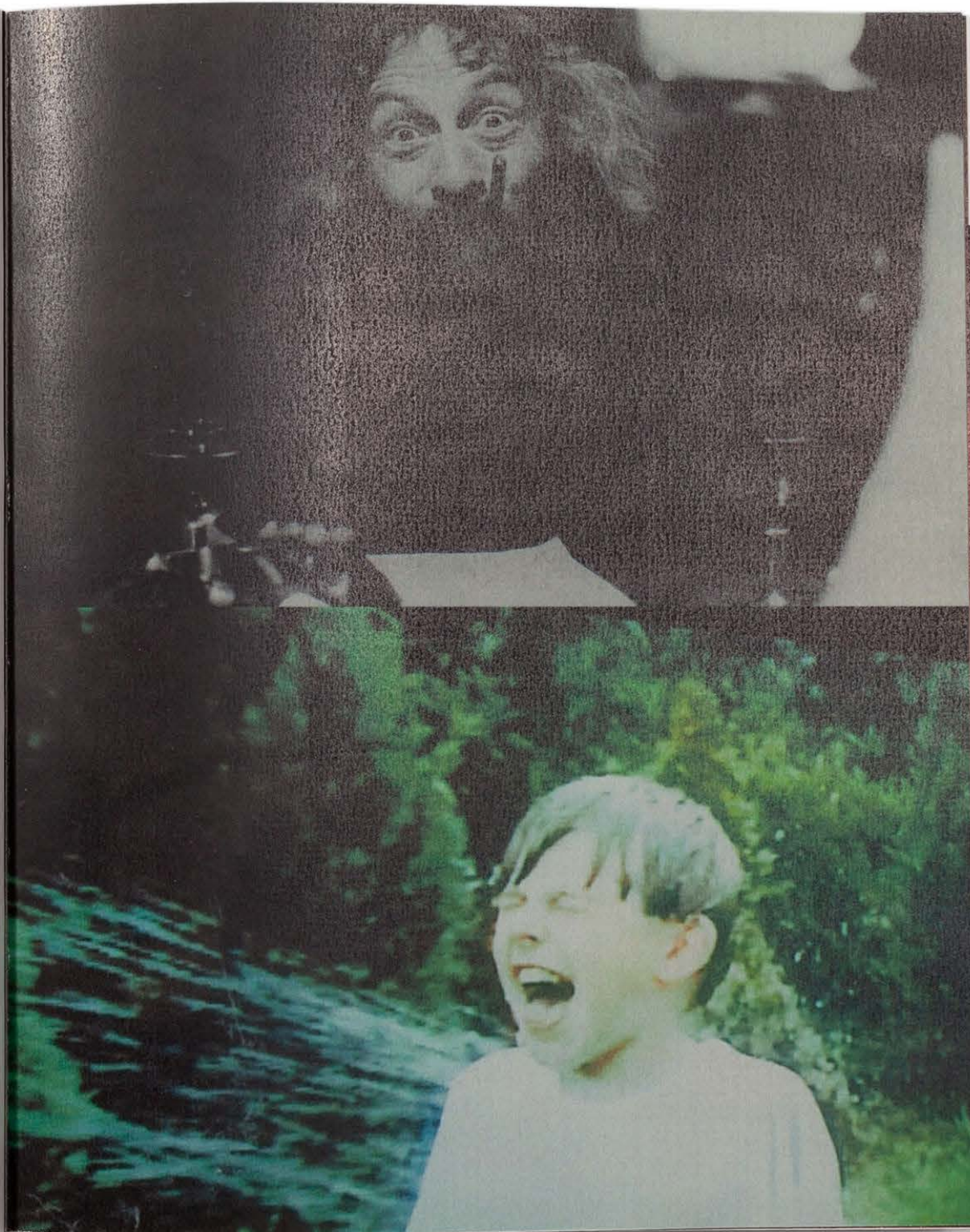

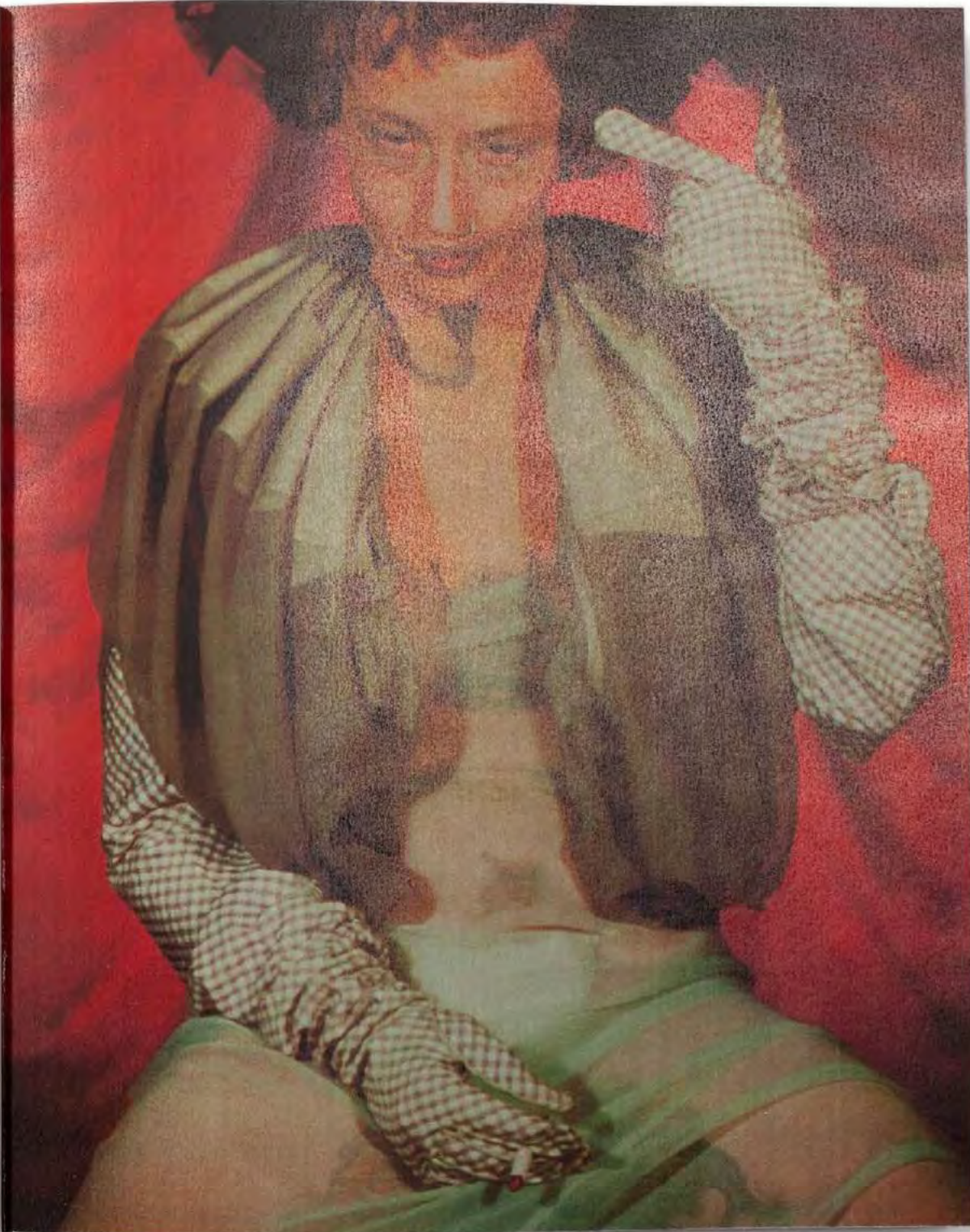
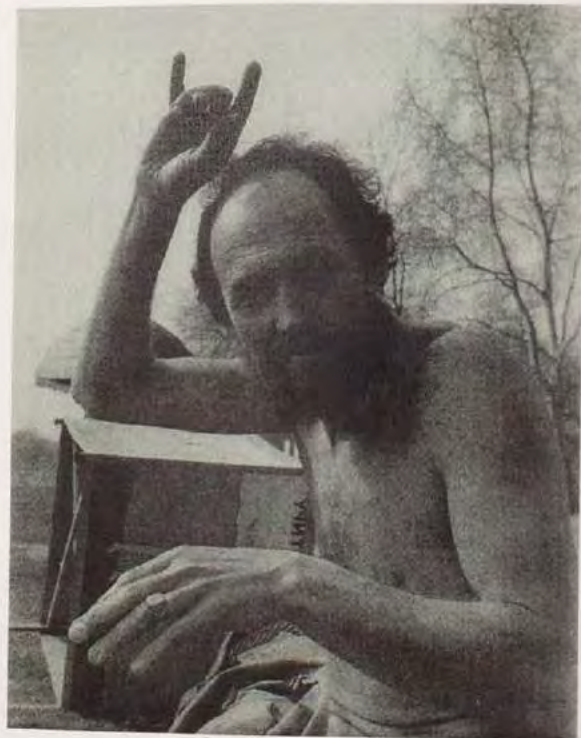



What is your favourite book nobody knows about?



Why weren't you an author yourself?



Conversation between Basit Hefli and Lukas Hefli. Basit is 21 years old lives in Switzerland and is a Graphic Designer. His brother Lukas Hefli is 22 and studying English literature.

Basit, 11:30 am, 01 September 2021. What have you read today?

Lukas, 11:30 am, 01 September 2021. To be fair I've read it before I just read it again because I do like the story. I think it is genius. So, 'The Black Cat' belongs to gothic fiction. It's a movement away from being so rational and unreliable narrators. Before the gothic, narrators were supposed to be reliable and when this movement started questioning the guy that's telling you the story, that's telling you the story, are you familiar with the story?

Basit, 11:30 am, 01 September 2021. Generally next, not specifically books. Well, I read a lot of things today. WhatsApp messages for example. I've read the weather forecast. I've done some google searches, so I suppose I've read those.

Lukas, 11:30 am, 01 September 2021. I know the general story, pretty sure I know it from you actually. Oh, so I'll sum it up read quick. So basically it's a guy who is sentenced to death and he's writing his last words. It is a dying man's words. Very honest, it was supposed to be. However, we are forced to question that when the narrator starts reconstructing his story. Mere homicide creates it when he sees hold events in what he sees to describe what's happening. He claims that he's not crazy despite what happens. He tries to show the story and depict it in a way that you will agree with him at the end. What happens is that he starts as a quiet kid that actually

preferred animals over humans. He married a woman and it was ok. It is a bit of a forced marriage if you read between the lines but he was ok with it. They got loads of animals and more specifically they got a black cat named Pluto. He loved the animal at first but then at some point it starts ticking him off for whatever reason, does not really know why, and he starts lashing out at the other animals first. Then he becomes an alcoholic and murders the cat, stabs out its eye.

Basit, 11:30 am, 01 September 2021. My problem with big books is that I don't get through them most of the time. Even if I've already read most of it, it's like an insurmountable barrier that stops me from finishing it.

Lukas, 11:30 am, 01 September 2021. From that perspective that does make sense. There are books that I've read, mainly translated books, where social interaction really suffers. Sometimes the interactions are just too methodically constructed

show up. They don't find anything to be starts bugging. All that point he recounts that there was a scratch in the wall, despite the fact that the cat was buried in there for four days. They broke open the wall and they found both the woman and the cat. I really like this story because not only does it go into all of that supernatural, questioning rationality, questioning the narrative itself while simultaneously telling what is basically a horror story while simultaneously showing that there is the capability of that devil within us. That devil him growing up to be this animal loving person, well, that is what he describes himself as, and then he goes completely haywire. My personal interpretation is that it is a criticism of the domestic conventions of the time period he lived in.

Basit, 11:30 am, 01 September 2021. How did you get it? From a bookstore. It was a big book and like big books.

Lukas, 11:30 am, 01 September 2021. Well, these are the books that I read when I come home from dancing or partying at 12 or sometimes 4 in the morning when I'm not ready to sleep yet. Then I don't want to read about existentialism. But I think what keeps me from getting bored is that I really focus on the social interactions in these books. Despite the main character not facing any problems they can't solve, the way that they do can teach me things.

Basit, 11:30 am, 01 September 2021. Why do you like big books? I can read them longer. Short stories are also nice of course but if you read through them in a day they're done.

Lukas, 11:30 am, 01 September 2021. I guess the difference with it for me is that I still learn something. I still analyse the interactions and can think about how they could be improved upon. A movie flows at its own predetermined pace while I can read in my own tempo. If I want to think about something for a minute I can do that. Movies also focus a lot on the visuals, which makes perfect sense but I personally would prefer the focus to be on the interactions.

Basit, 11:30 am, 01 September 2021. If I drop a book it's within the first few hundred pages.

Lukas, 11:30 am, 01 September 2021. Well, for me the problem with things like Marvel movies lies somewhere else. They are based on comics, and I love comics but I feel it's weird how they try to adapt that to a life action movie format. If you're reading a comic it all makes sense in its own reality because it's very clearly a

different world and so yours. You can put a lizard guy in there and as a reader, you just going to accept it. As soon as those designs and stories get into life action movies then get very weird very fast. Another great example for that would be the Lion King remake where they put the cartoonish, expressive movie and destroyed it by translating it into a visual language that I was never intended for.

Basit, 11:30 am, 01 September 2021. I was wondering if you still remember our conversation the other day about the topic 'reading'? My first question is: What have you read today?

Lukas, 11:30 am, 01 September 2021. I read my homework assignments and my horoscope. Besides, I was a lot on my phone, where I read some posts on Instagram and Twitter. I also read on my astrology app to see what the day has in store for me.

Basit, 11:30 am, 01 September 2021. Interesting! You know, generally, I'm not as much into astrology or witchcraft as you are, but I love to see you getting happy with it. I suppose spiritually books weren't the first ones for you to read. What is the first book you remember? Did you read it yourself or was it read to you? And was it in Spanish or English?

Lukas, 11:30 am, 01 September 2021. The first book I read was a book in Spanish called 'Tamará' and I remember reading it by myself. I ran into the author at a book convention when I was very little and I did not like the book before.

stay and untamed creativity. Also, I am aware of being perceived as a children's book but I disagree heavily with that.

Basit, 11:30 am, 01 September 2021. The first stories that I recall my picture books. For example, the tiger that goes to Panama. The first book that I read myself was 'Elder', which is a historical novel. I later found out it was a romance fiction which I completely missed at the time. It was set in common times and follows the story of a girl that lost her clan and gets adopted by a clan of Neanderthals.

Basit, 11:30 am, 01 September 2021. Looking at it from my perspective now it might be a bit of a problematic read. I was probably a bit too young.

Lukas, 11:30 am, 01 September 2021. How did you get it? From a bookstore. It was a big book and like big books.

Basit, 11:30 am, 01 September 2021. Why do you like big books? I can read them longer. Short stories are also nice of course but if you read through them in a day they're done.

Basit, 11:30 am, 01 September 2021. My problem with big books is that I don't get through them most of the time. Even if I've already read most of it, it's like an insurmountable barrier that stops me from finishing it.

Lukas, 11:30 am, 01 September 2021. From that perspective that does make sense. There are books that I've read, mainly translated books, where social interaction really suffers. Sometimes the interactions are just too methodically constructed

or if something happens that I don't agree with.

Basit, 11:30 am, 01 September 2021. What are your criteria to decide if it's a good book or not?

Lukas, 11:30 am, 01 September 2021. That's a big question. Because I read different books for different reasons. If it's a scientific book I have to contain the knowledge I am seeking. If I am reading leisure fiction I just want my brain to relax and not have to do any work at all and then I just read Mary Sue fiction. There's a main character and everything goes right and well.

Basit, 11:30 am, 01 September 2021. Where is the interest in that? I have a strong dislike for them, I feel like after having read one of them, you've read them all.

Lukas, 11:30 am, 01 September 2021. Well, these are the books that I read when I come home from dancing or partying at 12 or sometimes 4 in the morning when I'm not ready to sleep yet. Then I don't want to read about existentialism. But I think what keeps me from getting bored is that I really focus on the social interactions in these books. Despite the main character not facing any problems they can't solve, the way that they do can teach me things.

Basit, 11:30 am, 01 September 2021. Why do you like big books? I can read them longer. Short stories are also nice of course but if you read through them in a day they're done.

Basit, 11:30 am, 01 September 2021. My problem with big books is that I don't get through them most of the time. Even if I've already read most of it, it's like an insurmountable barrier that stops me from finishing it.

Basit, 11:30 am, 01 September 2021. How did you get it? From a bookstore. It was a big book and like big books.

Lukas, 11:30 am, 01 September 2021. Well, these are the books that I read when I come home from dancing or partying at 12 or sometimes 4 in the morning when I'm not ready to sleep yet. Then I don't want to read about existentialism. But I think what keeps me from getting bored is that I really focus on the social interactions in these books. Despite the main character not facing any problems they can't solve, the way that they do can teach me things.

Basit, 11:30 am, 01 September 2021. Why do you like big books? I can read them longer. Short stories are also nice of course but if you read through them in a day they're done.

Basit, 11:30 am, 01 September 2021. My problem with big books is that I don't get through them most of the time. Even if I've already read most of it, it's like an insurmountable barrier that stops me from finishing it.

Lukas, 11:30 am, 01 September 2021. From that perspective that does make sense. There are books that I've read, mainly translated books, where social interaction really suffers. Sometimes the interactions are just too methodically constructed

show up. They don't find anything to be starts bugging. All that point he recounts that there was a scratch in the wall, despite the fact that the cat was buried in there for four days. They broke open the wall and they found both the woman and the cat. I really like this story because not only does it go into all of that supernatural, questioning rationality, questioning the narrative itself while simultaneously telling what is basically a horror story while simultaneously showing that there is the capability of that devil within us. That devil him growing up to be this animal loving person, well, that is what he describes himself as, and then he goes completely haywire. My personal interpretation is that it is a criticism of the domestic conventions of the time period he lived in.

Basit, 11:30 am, 01 September 2021. How did you get it? From a bookstore. It was a big book and like big books.

Basit, 11:30 am, 01 September 2021. Why do you like big books? I can read them longer. Short stories are also nice of course but if you read through them in a day they're done.

Basit, 11:30 am, 01 September 2021. My problem with big books is that I don't get through them most of the time. Even if I've already read most of it, it's like an insurmountable barrier that stops me from finishing it.

Lukas, 11:30 am, 01 September 2021. From that perspective that does make sense. There are books that I've read, mainly translated books, where social interaction really suffers. Sometimes the interactions are just too methodically constructed

show up. They don't find anything to be starts bugging. All that point he recounts that there was a scratch in the wall, despite the fact that the cat was buried in there for four days. They broke open the wall and they found both the woman and the cat. I really like this story because not only does it go into all of that supernatural, questioning rationality, questioning the narrative itself while simultaneously telling what is basically a horror story while simultaneously showing that there is the capability of that devil within us. That devil him growing up to be this animal loving person, well, that is what he describes himself as, and then he goes completely haywire. My personal interpretation is that it is a criticism of the domestic conventions of the time period he lived in.

Basit, 11:30 am, 01 September 2021. How did you get it? From a bookstore. It was a big book and like big books.

Lukas, 11:30 am, 01 September 2021. Well, these are the books that I read when I come home from dancing or partying at 12 or sometimes 4 in the morning when I'm not ready to sleep yet. Then I don't want to read about existentialism. But I think what keeps me from getting bored is that I really focus on the social interactions in these books. Despite the main character not facing any problems they can't solve, the way that they do can teach me things.

Basit, 11:30 am, 01 September 2021. Why do you like big books? I can read them longer. Short stories are also nice of course but if you read through them in a day they're done.

Basit, 11:30 am, 01 September 2021. My problem with big books is that I don't get through them most of the time. Even if I've already read most of it, it's like an insurmountable barrier that stops me from finishing it.

Lukas, 11:30 am, 01 September 2021. From that perspective that does make sense. There are books that I've read, mainly translated books, where social interaction really suffers. Sometimes the interactions are just too methodically constructed

show up. They don't find anything to be starts bugging. All that point he recounts that there was a scratch in the wall, despite the fact that the cat was buried in there for four days. They broke open the wall and they found both the woman and the cat. I really like this story because not only does it go into all of that supernatural, questioning rationality, questioning the narrative itself while simultaneously telling what is basically a horror story while simultaneously showing that there is the capability of that devil within us. That devil him growing up to be this animal loving person, well, that is what he describes himself as, and then he goes completely haywire. My personal interpretation is that it is a criticism of the domestic conventions of the time period he lived in.

Basit, 11:30 am, 01 September 2021. How did you get it? From a bookstore. It was a big book and like big books.

Lukas, 11:30 am, 01 September 2021. Well, these are the books that I read when I come home from dancing or partying at 12 or sometimes 4 in the morning when I'm not ready to sleep yet. Then I don't want to read about existentialism. But I think what keeps me from getting bored is that I really focus on the social interactions in these books. Despite the main character not facing any problems they can't solve, the way that they do can teach me things.

Basit, 11:30 am, 01 September 2021. Why do you like big books? I can read them longer. Short stories are also nice of course but if you read through them in a day they're done.

Basit, 11:30 am, 01 September 2021. My problem with big books is that I don't get through them most of the time. Even if I've already read most of it, it's like an insurmountable barrier that stops me from finishing it.

Lukas, 11:30 am, 01 September 2021. From that perspective that does make sense. There are books that I've read, mainly translated books, where social interaction really suffers. Sometimes the interactions are just too methodically constructed

show up. They don't find anything to be starts bugging. All that point he recounts that there was a scratch in the wall, despite the fact that the cat was buried in there for four days. They broke open the wall and they found both the woman and the cat. I really like this story because not only does it go into all of that supernatural, questioning rationality, questioning the narrative itself while simultaneously telling what is basically a horror story while simultaneously showing that there is the capability of that devil within us. That devil him growing up to be this animal loving person, well, that is what he describes himself as, and then he goes completely haywire. My personal interpretation is that it is a criticism of the domestic conventions of the time period he lived in.

Basit, 11:30 am, 01 September 2021. How did you get it? From a bookstore. It was a big book and like big books.

Lukas, 11:30 am, 01 September 2021. Well, these are the books that I read when I come home from dancing or partying at 12 or sometimes 4 in the morning when I'm not ready to sleep yet. Then I don't want to read about existentialism. But I think what keeps me from getting bored is that I really focus on the social interactions in these books. Despite the main character not facing any problems they can't solve, the way that they do can teach me things.

Basit, 11:30 am, 01 September 2021. Why do you like big books? I can read them longer. Short stories are also nice of course but if you read through them in a day they're done.

Basit, 11:30 am, 01 September 2021. My problem with big books is that I don't get through them most of the time. Even if I've already read most of it, it's like an insurmountable barrier that stops me from finishing it.

Lukas, 11:30 am, 01 September 2021. From that perspective that does make sense. There are books that I've read, mainly translated books, where social interaction really suffers. Sometimes the interactions are just too methodically constructed

show up. They don't find anything to be starts bugging. All that point he recounts that there was a scratch in the wall, despite the fact that the cat was buried in there for four days. They broke open the wall and they found both the woman and the cat. I really like this story because not only does it go into all of that supernatural, questioning rationality, questioning the narrative itself while simultaneously telling what is basically a horror story while simultaneously showing that there is the capability of that devil within us. That devil him growing up to be this animal loving person, well, that is what he describes himself as, and then he goes completely haywire. My personal interpretation is that it is a criticism of the domestic conventions of the time period he lived in.

Basit, 11:30 am, 01 September 2021. How did you get it? From a bookstore. It was a big book and like big books.

Lukas, 11:30 am, 01 September 2021. Well, these are the books that I read when I come home from dancing or partying at 12 or sometimes 4 in the morning when I'm not ready to sleep yet. Then I don't want to read about existentialism. But I think what keeps me from getting bored is that I really focus on the social interactions in these books. Despite the main character not facing any problems they can't solve, the way that they do can teach me things.

Basit, 11:30 am, 01 September 2021. Why do you like big books? I can read them longer. Short stories are also nice of course but if you read through them in a day they're done.

Basit, 11:30 am, 01 September 2021. My problem with big books is that I don't get through them most of the time. Even if I've already read most of it, it's like an insurmountable barrier that stops me from finishing it.

Lukas, 11:30 am, 01 September 2021. From that perspective that does make sense. There are books that I've read, mainly translated books, where social interaction really suffers. Sometimes the interactions are just too methodically constructed

show up. They don't find anything to be starts bugging. All that point he recounts that there was a scratch in the wall, despite the fact that the cat was buried in there for four days. They broke open the wall and they found both the woman and the cat. I really like this story because not only does it go into all of that supernatural, questioning rationality, questioning the narrative itself while simultaneously telling what is basically a horror story while simultaneously showing that there is the capability of that devil within us. That devil him growing up to be this animal loving person, well, that is what he describes himself as, and then he goes completely haywire. My personal interpretation is that it is a criticism of the domestic conventions of the time period he lived in.

Conversation between Alejandra Carrillo and Jofia Hefli. Alejandra Carrillo is 20 years old and studies audio visual in Guadalajara, Mexico. Jofia Hefli is 18 years old and studies at Fachhochschule Graftlh in Lucerne, Switzerland.

Basit, 11:30 am, 01 September 2021. I was wondering if you still remember our conversation the other day about the topic 'reading'? My first question is: What have you read today?

Alejandra, 11:30 am, 01 September 2021. I read my homework assignments and my horoscope. Besides, I was a lot on my phone, where I read some posts on Instagram and Twitter. I also read on my astrology app to see what the day has in store for me.

Jofia, 11:30 am, 01 September 2021. Interesting! You know, generally, I'm not as much into astrology or witchcraft as you are, but I love to see you getting happy with it. I suppose spiritually books weren't the first ones for you to read. What is the first book you remember? Did you read it yourself or was it read to you? And was it in Spanish or English?

Alejandra, 11:30 am, 01 September 2021. The first book I read was a book in Spanish called 'Tamará' and I remember reading it by myself. I ran into the author at a book convention when I was very little and I did not like the book before.

Jofia, 11:30 am, 01 September 2021. Well, for me the problem with things like Marvel movies lies somewhere else. They are based on comics, and I love comics but I feel it's weird how they try to adapt that to a life action movie format. If you're reading a comic it all makes sense in its own reality because it's very clearly a

different world and so yours. You can put a lizard guy in there and as a reader, you just going to accept it. As soon as those designs and stories get into life action movies then get very weird very fast. Another great example for that would be the Lion King remake where they put the cartoonish, expressive movie and destroyed it by translating it into a visual language that I was never intended for.

Basit, 11:30 am, 01 September 2021. I was wondering if you still remember our conversation the other day about the topic 'reading'? My first question is: What have you read today?

Alejandra, 11:30 am, 01 September 2021. I read my homework assignments and my horoscope. Besides, I was a lot on my phone, where I read some posts on Instagram and Twitter. I also read on my astrology app to see what the day has in store for me.

Jofia, 11:30 am, 01 September 2021. Interesting! You know, generally, I'm not as much into astrology or witchcraft as you are, but I love to see you getting happy with it. I suppose spiritually books weren't the first ones for you to read. What is the first book you remember? Did you read it yourself or was it read to you? And was it in Spanish or English?

Alejandra, 11:30 am, 01 September 2021. The first book I read was a book in Spanish called 'Tamará' and I remember reading it by myself. I ran into the author at a book convention when I was very little and I did not like the book before.

Jofia, 11:30 am, 01 September 2021. Well, for me the problem with things like Marvel movies lies somewhere else. They are based on comics, and I love comics but I feel it's weird how they try to adapt that to a life action movie format. If you're reading a comic it all makes sense in its own reality because it's very clearly a

different world and so yours. You can put a lizard guy in there and as a reader, you just going to accept it. As soon as those designs and stories get into life action movies then get very weird very fast. Another great example for that would be the Lion King remake where they put the cartoonish, expressive movie and destroyed it by translating it into a visual language that I was never intended for.

Basit, 11:30 am, 01 September 2021. I was wondering if you still remember our conversation the other day about the topic 'reading'? My first question is: What have you read today?

Alejandra, 11:30 am, 01 September 2021. I read my homework assignments and my horoscope. Besides, I was a lot on my phone, where I read some posts on Instagram and Twitter. I also read on my astrology app to see what the day has in store for me.

Jofia, 11:30 am, 01 September 2021. Interesting! You know, generally, I'm not as much into astrology or witchcraft as you are, but I love to see you getting happy with it. I suppose spiritually books weren't the first ones for you to read. What is the first book you remember? Did you read it yourself or was it read to you? And was it in Spanish or English?

Alejandra, 11:30 am, 01 September 2021. The first book I read was a book in Spanish called 'Tamará' and I remember reading it by myself. I ran into the author at a book convention when I was very little and I did not like the book before.

Jofia, 11:30 am, 01 September 2021. Well, for me the problem with things like Marvel movies lies somewhere else. They are based on comics, and I love comics but I feel it's weird how they try to adapt that to a life action movie format. If you're reading a comic it all makes sense in its own reality because it's very clearly a

different world and so yours. You can put a lizard guy in there and as a reader, you just going to accept it. As soon as those designs and stories get into life action movies then get very weird very fast. Another great example for that would be the Lion King remake where they put the cartoonish, expressive movie and destroyed it by translating it into a visual language that I was never intended for.

Basit, 11:30 am, 01 September 2021. I was wondering if you still remember our conversation the other day about the topic 'reading'? My first question is: What have you read today?

Alejandra, 11:30 am, 01 September 2021. I read my homework assignments and my horoscope. Besides, I was a lot on my phone, where I read some posts on Instagram and Twitter. I also read on my astrology app to see what the day has in store for me.

Jofia, 11:30 am, 01 September 2021. Interesting! You know, generally, I'm not as much into astrology or witchcraft as you are, but I love to see you getting happy with it. I suppose spiritually books weren't the first ones for you to read. What is the first book you remember? Did you read it yourself or was it read to you? And was it in Spanish or English?

Alejandra, 11:30 am, 01 September 2021. The first book I read was a book in Spanish called 'Tamará' and I remember reading it by myself. I ran into the author at a book convention when I was very little and I did not like the book before.

Jofia, 11:30 am, 01 September 2021. Well, for me the problem with things like Marvel movies lies somewhere else. They are based on comics, and I love comics but I feel it's weird how they try to adapt that to a life action movie format. If you're reading a comic it all makes sense in its own reality because it's very clearly a

different world and so yours. You can put a lizard guy in there and as a reader, you just going to accept it. As soon as those designs and stories get into life action movies then get very weird very fast. Another great example for that would be the Lion King remake where they put the cartoonish, expressive movie and destroyed it by translating it into a visual language that I was never intended for.

Basit, 11:30 am, 01 September 2021. I was wondering if you still remember our conversation the other day about the topic 'reading'? My first question is: What have you read today?

Alejandra, 11:30 am, 01 September 2021. I read my homework assignments and my horoscope. Besides, I was a lot on my phone, where I read some posts on Instagram and Twitter. I also read on my astrology app to see what the day has in store for me.

Jofia, 11:30 am, 01 September 2021. Interesting! You know, generally, I'm not as much into astrology or witchcraft as you are, but I love to see you getting happy with it. I suppose spiritually books weren't the first ones for you to read. What is the first book you remember? Did you read it yourself or was it read to you? And was it in Spanish or English?

Alejandra, 11:30 am, 01 September 2021. The first book I read was a book in Spanish called 'Tamará' and I remember reading it by myself. I ran into the author at a book convention when I was very little and I did not like the book before.

Jofia, 11:30 am, 01 September 2021. Well, for me the problem with things like Marvel movies lies somewhere else. They are based on comics, and I love comics but I feel it's weird how they try to adapt that to a life action movie format. If you're reading a comic it all makes sense in its own reality because it's very clearly a

different world and so yours. You can put a lizard guy in there and as a reader, you just going to accept it. As soon as those designs and stories get into life action movies then get very weird very fast. Another great example for that would be the Lion King remake where they put the cartoonish, expressive movie and destroyed it by translating it into a visual language that I was never intended for.

Basit, 11:30 am, 01 September 2021. I was wondering if you still remember our conversation the other day about the topic 'reading'? My first question is: What have you read today?

Alejandra, 11:30 am, 01 September 2021. I read my homework assignments and my horoscope. Besides, I was a lot on my phone, where I read some posts on Instagram and Twitter. I also read on my astrology app to see what the day has in store for me.

Jofia, 11:30 am, 01 September 2021. Interesting! You know, generally, I'm not as much into astrology or witchcraft as you are, but I love to see you getting happy with it. I suppose spiritually books weren't the first ones for you to read. What is the first book you remember? Did you read it yourself or was it read to you? And was it in Spanish or English?

Alejandra, 11:30 am, 01 September 2021. The first book I read was a book in Spanish called 'Tamará' and I remember reading it by myself. I ran into the author at a book convention when I was very little and I did not like the book before.

Jofia, 11:30 am, 01 September 2021. Well, for me the problem with things like Marvel movies lies somewhere else. They are based on comics, and I love comics but I feel it's weird how they try to adapt that to a life action movie format. If you're reading a comic it all makes sense in its own reality because it's very clearly a



Divine, 1975

3:40 p.m.  
Made me laugh? Yeah, sure. I've read a couple of biographies and if the person tells a funny story obviously, I'll laugh.

but then probably most of the people in my age have not.

3:41 p.m.  
Do you laugh out loud?

3:45 p.m.  
Yes, for sure, but I also think we should carry on the tradition?

3:45 p.m.  
Yeaah, but then again do you have to read all the Dickens...

3:41 p.m.  
No, I cringe out loud.

3:41 p.m.  
And did you ever cry because of a book?

3:45 p.m.  
Certainly not...

3:42 p.m.  
Pretty much every book. man. it's so bad, I just start crying at random times. I don't even have to relate to the character, it just has to be sad. I am also the person that starts crying in the cinema and what not, so...

3:45 p.m.  
Do you regret not reading anything?

3:45 p.m.  
I bought 'Oliver Twist' and I started it but it's just so different than any books I've read so far. I'd have to get used to it first... it's also just kind of tedious. Is there a book you have tried to read but couldn't finish?

3:42 p.m.  
Yeah, me too. I think the last time I remember crying because of a book is in 'Harry Potter' six, when Dumbledore died... Is there a book you feel guilty to not have read?

3:46 p.m.  
I think I give a book a good 50 to 80 pages and if it has not convinced me by then...

3:43 p.m.  
So many, so many books. Just because of my dad and my sister, they are both completely into books. They have read all of the classics. I have read some of the Jane Austens and I've got plans to read a Dickens, but I haven't got around to it. So, I do feel guilty that I have not read some books,

3:46 p.m.  
That's a lot.

3:46 p.m.  
Yeah, that is a lot. People usually give them 30 or something. I like to give it a chance. That's why I always give it 80 pages, and if I still do not like it by then I am just not gonna finish it ever. What about you?

3:46 p.m.  
I rarely read the books I get as a present. I don't know why. Most of the time it is just not me. There are so many factors that I have to consider. The design for example.

3:46 p.m.  
I think to me the design does matter. If I go into to the bookshop, then obviously I'm gonna pick a book that I like. But if somebody tells me oh that's a great book and the cover is just hideous, I'm still gonna read it because the person told me it is good.

3:47 p.m.  
Yeah, me too. Do you know the After series?

3:47 p.m.  
Didn't that start from a fan fiction?

3:47 p.m.  
Yeah! I think that's the cool thing!

3:48 p.m.  
Ugh, I hate it.

3:49 p.m.  
No, that's so cool, because the main character is based on Harry Styles.

3:49 p.m.  
Yeah, that I know.

3:49 p.m.  
I just think it's so cool that something like that became so big, don't you think?

3:50 p.m.  
I mean I'm happy for the author that her fan fiction got into a book. It was a good fan fiction. It doesn't mean it's gonna be a bestselling novel. If you know what I mean.

3:50 p.m.  
Yeah, for sure. So, do you always read novels? Oh, and you also said you read biographies?

3:51 p.m.  
Yeah. But I prefer romance novels. I do not like fantasy, just because... Well, it depends, Lord Of The Rings, Hobbit and Harry Potter type of fantasy, I get that, but then fantasy with dragons and princesses...

3:51 p.m.  
In literally every book you just named are dragons involved.

3:52 p.m.  
Yeah okay, but dragons aren't the main plot of the story. I just don't like fantasies. It's just not my genre. I would say most of all I read novels.

3:52 p.m.  
Romances?

3:52 p.m.  
Especially yeah, I don't know why. Actually, it doesn't even have to be a romance, just something that plays in the present.

3:52 p.m.  
What is your motivation for reading? Is it just for entertainment or self-help, information, curiosity, or anything like that?

3:53 p.m.  
Uhm, it is definitely not for self-help, because then I'd have to read something else than romance novels.

3:53 p.m.  
Both laugh. I think it is also not really curiosity. I just like escaping the real world, and then just forgetting about things like Covid. During Lockdown I read fucking loads. I did actually read loads, okay?

3:53 p.m.  
Both laugh. That's one of the big parts for me just like being in a different world. That's why I would never read a novel where Corona is a thing. Why do you read?

3:53 p.m.  
Same reason, just for entertainment. It's the same as watching a movie. But you feel less guilty because you're still doing something, instead of just lying there and doing nothing.

3:54 p.m.  
Yeah, and you feel more intelligent. Both laugh.

3:54 p.m.  
Have you ever read a book where also a film version exists?

3:54 p.m.  
Yeah. Well, I read Harry Potter, all of them. And I did that kind of while

I was also watching the films. So, I read the first one and then watched the movie.

3:54 p.m.  
Same with me.

3:54 p.m.  
Just because I liked to compare the two.

3:55 p.m.  
In which order do you prefer it? If you first read the book and then watch the movie or...

3:55 p.m.  
I like to first read the book and then watch the movie. But if the book got written as a film and turned into a book, then I'd rather watch the film first. Just because it is the original form.

3:56 p.m.  
Yeah, the other way around is committing a crime.

3:56 p.m.  
Also, sometimes the author didn't get a say in the film. And that is when things aren't the way they should have been.

3:56 p.m.  
Also, most of the time the movie is just not as good as the book.

3:57 p.m.  
Yeah, it's like you said the other way around it is a crime.

3:57 p.m.  
How many books roughly do you own?

3:57 p.m.  
Well... If I had more money probably more. Sixty? I don't know.

3:57 p.m.  
That's a lot.

3:57 p.m.  
But I have not read all of them.

3:57 p.m.  
Yeah, I have about forty books. And I still did not manage to read all of them. So, where do you read?

3:57 p.m.  
Mostly in my bed I'd say. Because its warm and what not. Also, in the summer at scouts' camp I read in the middle of the forest, that was nice. Loads of insects though.

3:58 p.m.  
Yes, that's true, but I also like to read in nature, for example in the hammock under the trees at my parents' house. It's beautiful. Did you ever didn't go to bed because of reading?

3:58 p.m.  
OOH! So often. And then I'm so tired the next day.

3:58 p.m.  
That's why I don't choose to read during school time because I know if I like the book, I have to read it and I can not stop.

3:58 p.m.  
I'll just stop myself at the end of the chapter.

3:58 p.m.  
Yeah, for me it is not that easy, I'll just always tell myself one more chapter and then it never ends. Do you have any book recommendations?

3:58 p.m.  
Probably too many, but I'd say 'We Were Liars', the one I am reading right now. Even though I'm not finished with it yet. So, the ending might be shit, I will come back to you on that. Also, I don't know if you've ever read 'Pride and Prejudice'?

3:59 p.m.  
No, but I saw the movie. I guess the book is better though.

3:59 p.m.  
A hundred percent. So, 'Pride and Prejudice' definitely, and 'The Sun is Also a Star'. Read it. That is the one that actually got me back into reading.



What do you think about the website, which was made for you?



Where would you have spent your money, if not for your books?

Conversation between Hannah and Paula.  
Hannah from South Carolina, she is studying environmental science.  
Paula is 20 years old lives Zug, Switzerland, she is a Graphic Design student.

Hannah 4:14 p.m., 29 August 2021  
Hi Paula, this is Hannah.

Paula 4:14 p.m.  
Hello! So, are you reading a book at the moment?

4:15 p.m.  
Yes it's called Braiding Sweetgrass by Robin Wall Kimmerer.

4:16 p.m.  
I don't know this book, what is it about?

4:18 p.m.  
The author is a Native American scientist, and she combines western science and traditional indigenous knowledge to describe the natural world. Very beautiful book.

4:22 p.m.  
Wow sounds interesting. Do you prefer to read nonfiction books? Because I don't really like to read, except novels.

4:24 p.m.  
I am studying environmental science in college, so I do love scientific literature. But her writing also incorporates Native American myths and history into it. It is not dry and boring like a science textbook. It is really beautifully written.

4:25 p.m.  
I have to give it a try. Is it your favourite book?

4:26 p.m.  
Yes, it's my favourite book right now. I think everyone should read this book. It teaches you how to have a good relationship with the earth. To also give back instead of just take.

4:29 p.m.  
That's a very topical issue at the moment, do you get emotionally involved when you read?

4:30 p.m.  
Yes, I do. I think reading is very much about emotion - if it is written well. People would not read if it didn't entertain their emotions in some way.

4:35 p.m.  
Makes sense. I think I don't like to read books that much because I had to read very boring books in school. But one book I read was very nice, it's called After and it is written by Anna Todd. Do you know it?

4:35 p.m.  
I felt the same way after graduating high school. But eventually I found my way back to reading again by finding books that

genuinely interested me. No I have not. What genre is it?

4:36 p.m.  
I think it's a novel. There is also a new movie but it is horrible and not like the book. Have you experienced that as well? That the book is very good but nothing like the movie?

4:38 p.m.  
Is it like a young adult romance book? Yes, it is upsetting when they mess up the movie.

4:40 p.m.  
Yes, exactly. Is there a book you hated to read that you couldn't finish reading?

4:40 p.m.  
Yes, it was called Catcher in the Rye. I think every American high school makes their students read this book at some point. It is considered a classic. It's so boring.

4:42 p.m.  
I've never heard of that book but we also have a book in Switzerland like that, it's called Effi Briest. What makes the book so boring?

4:51 p.m.  
I don't like the style of the writing and the plot is very

slow and uninteresting in my opinion. It's about a trouble high school boy going to boarding school in New England.

4:55 p.m.  
I know what you mean, should that book teach the students something?

4:57 p.m.  
The book is supposed to be about growing up and the fears and anxiety and courage that come with that.

4:59 p.m.  
Does not sound that bad. Is there a book that has changed your view on anything? Like the world, yourself or a friendship etc.

5:08 p.m.  
It's very dry but a lot of people like it. Yes, the book I am currently reading - Braiding Sweet Grass, changed my view on human relationship with earth.

5:11 p.m.  
What was your opinion before reading the book and how exactly did the book change your mind?

5:17 p.m.  
That humans can only have a negative impact on the environment, but the native Americans

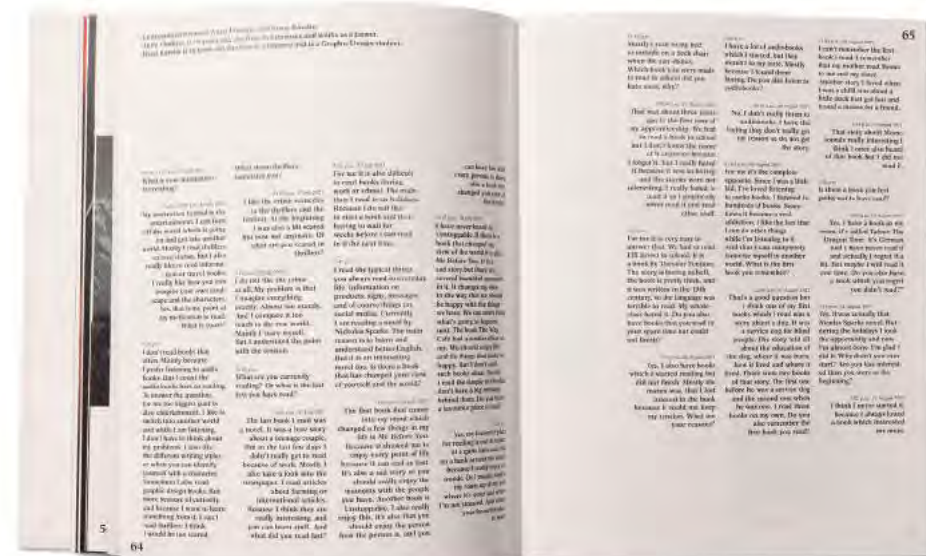

# 04 DELIQUESCE *EYES*

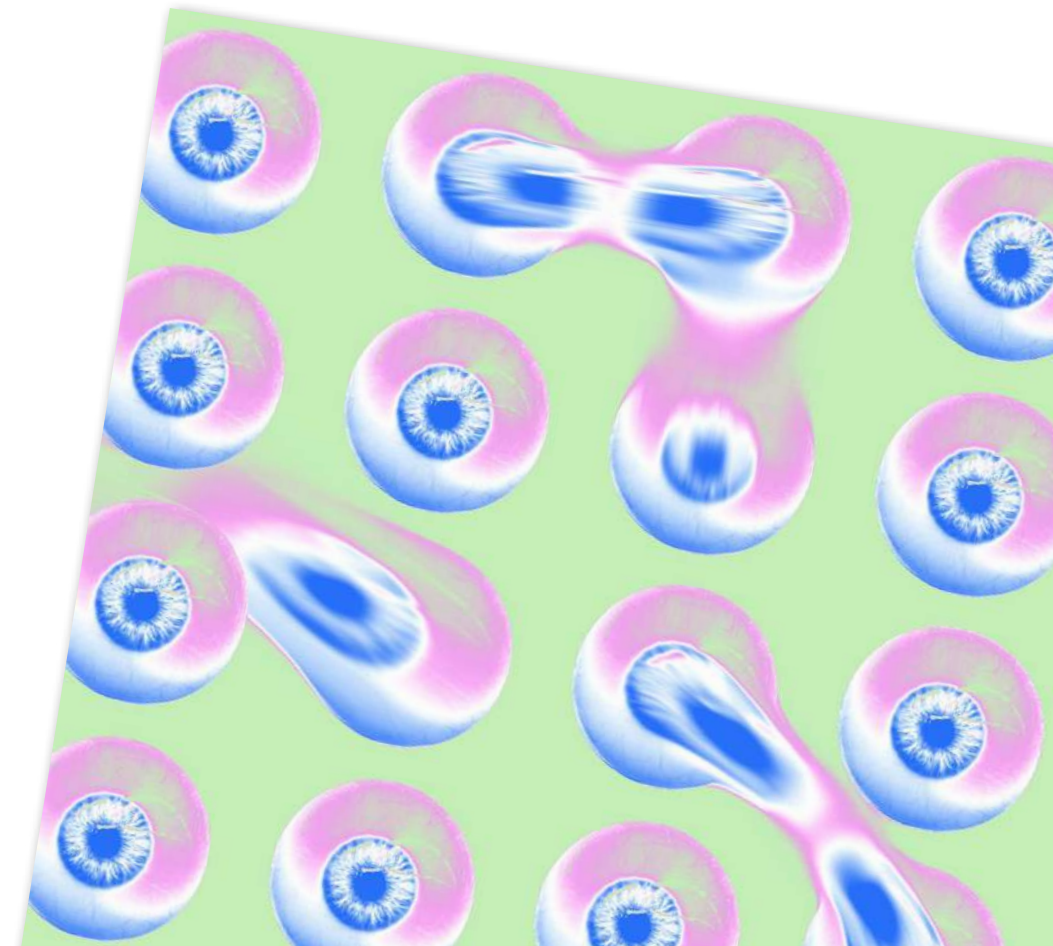

Eyes morphing into and against each other. In this experimental project I designed five postcards. There were not many restrictions but the cards had to be colourful. The topics were words such as repetition, copy, gradient, and loop. Here I could let my fondness for colours roam free. Even though the eyes could be perceived as disturbing or eerie, the lively and joyous colours turned the abstract composition of eyes into a bright postcard.

LECTURERS  
Martin Infanger  
Fabio Parizzi  
Moritz Profitlich  
Markus Wicki

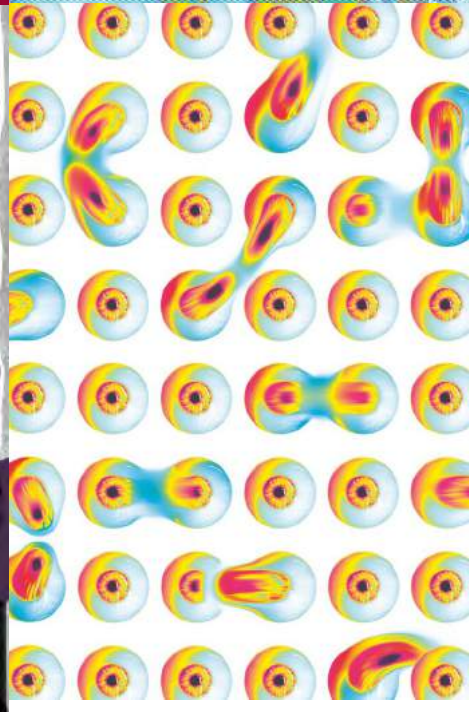
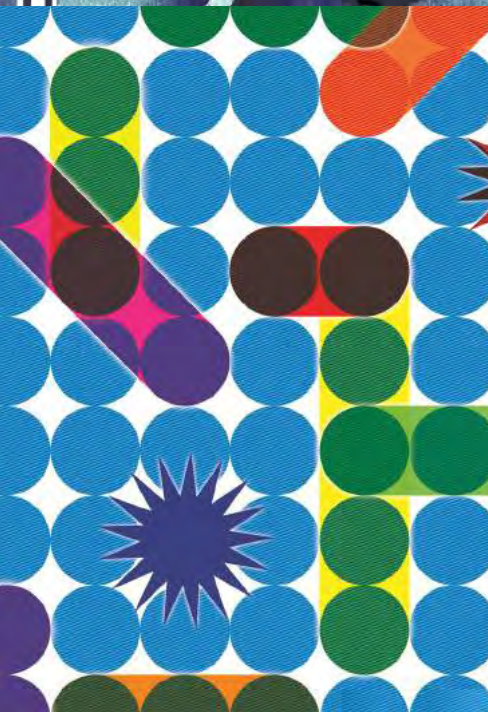
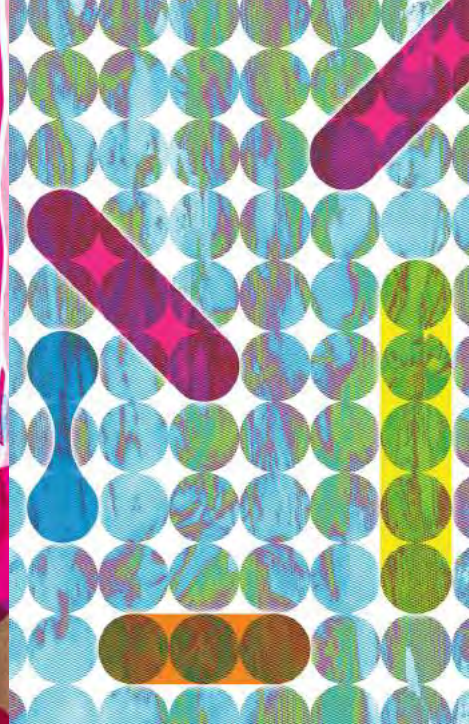
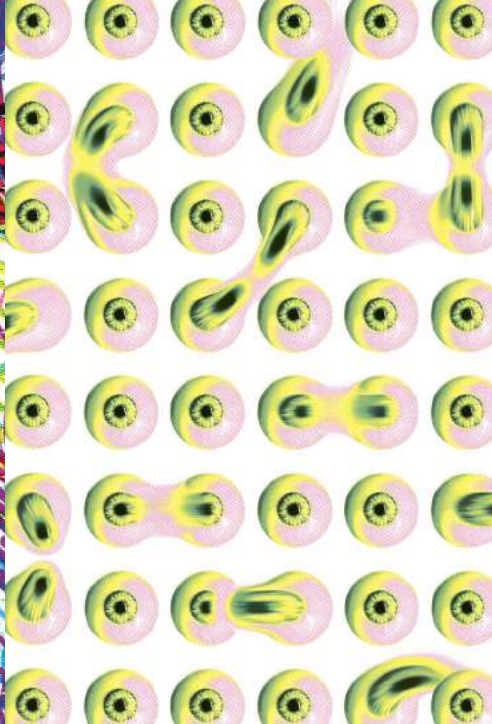
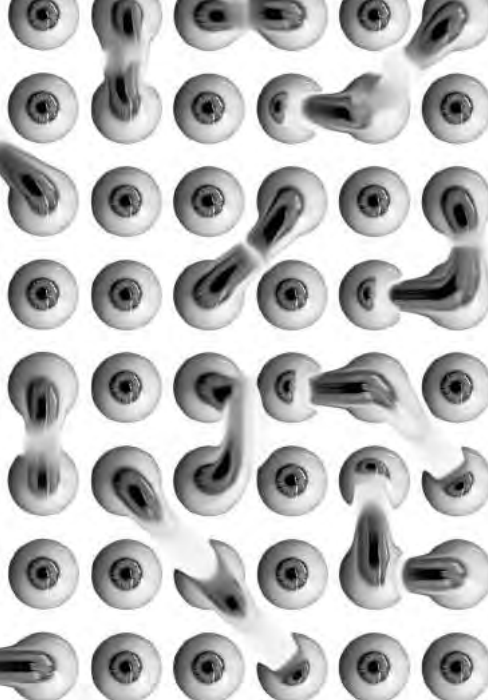

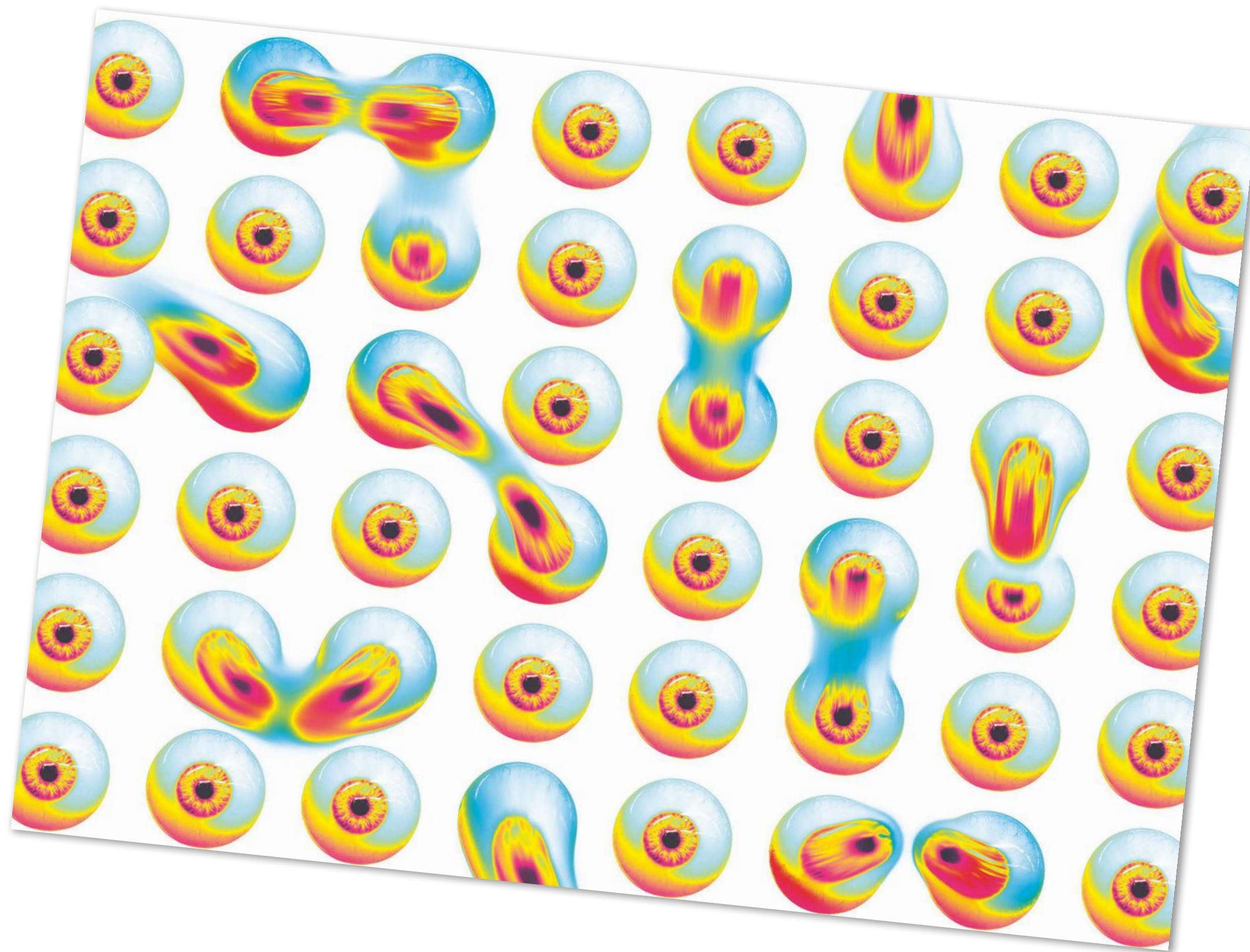

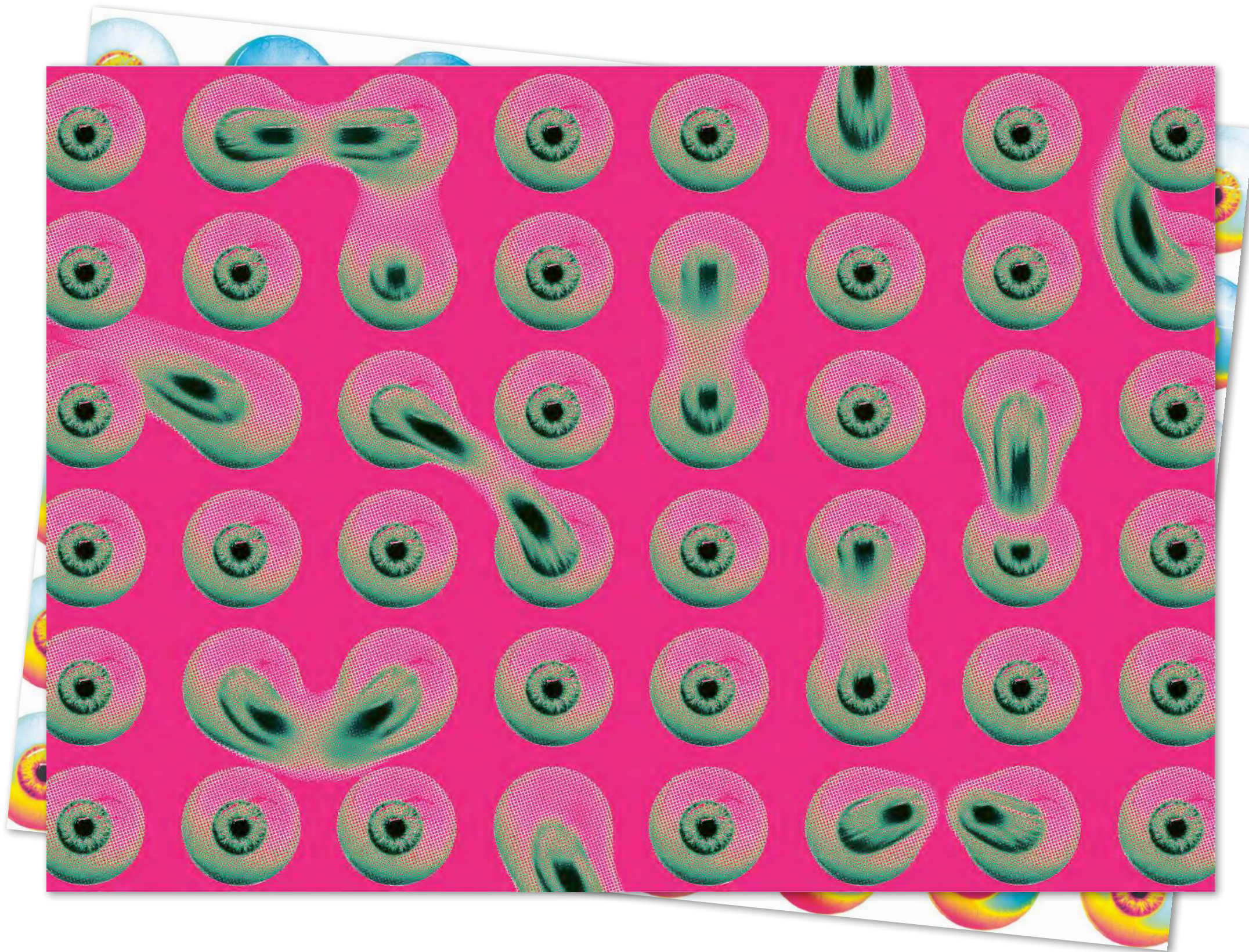

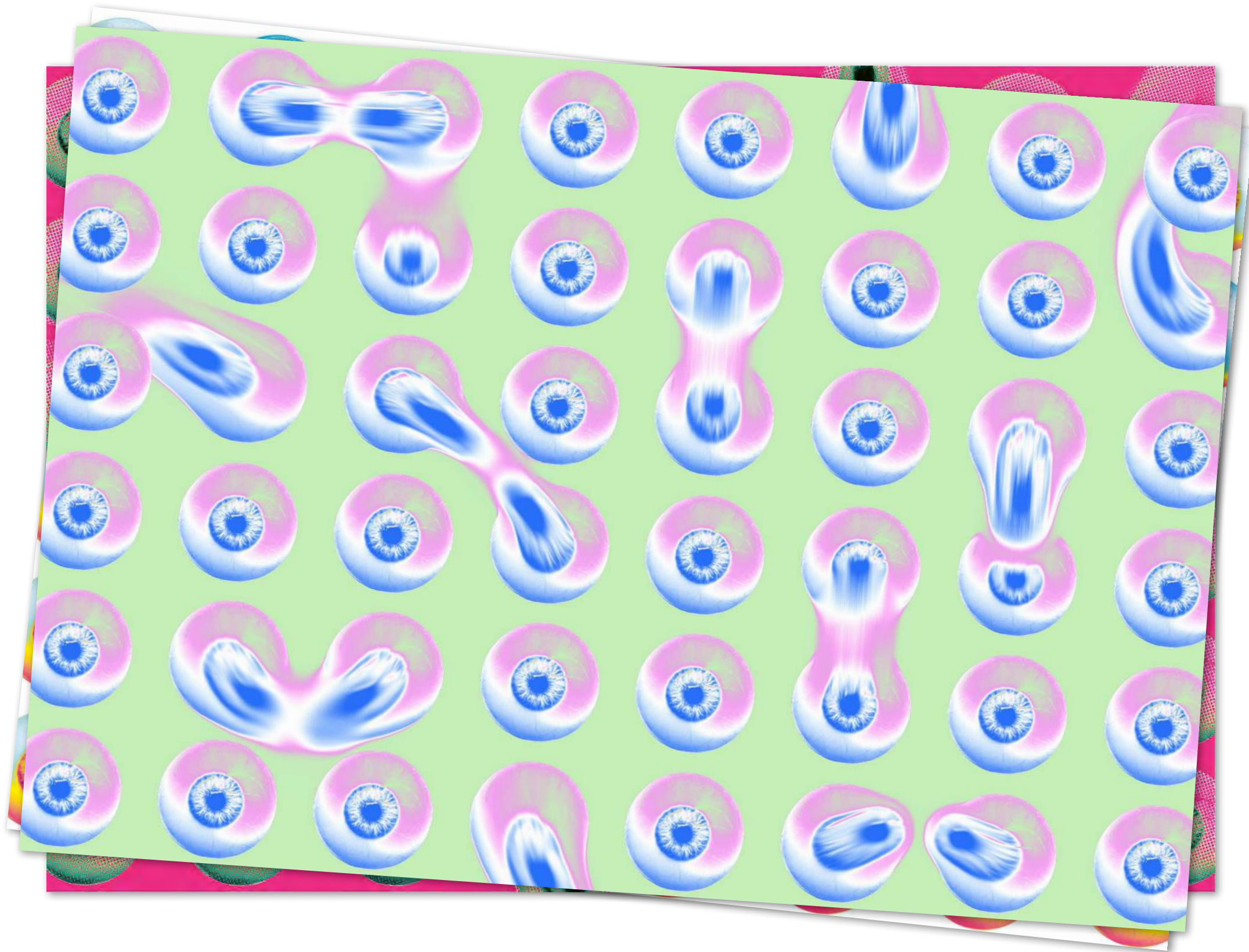

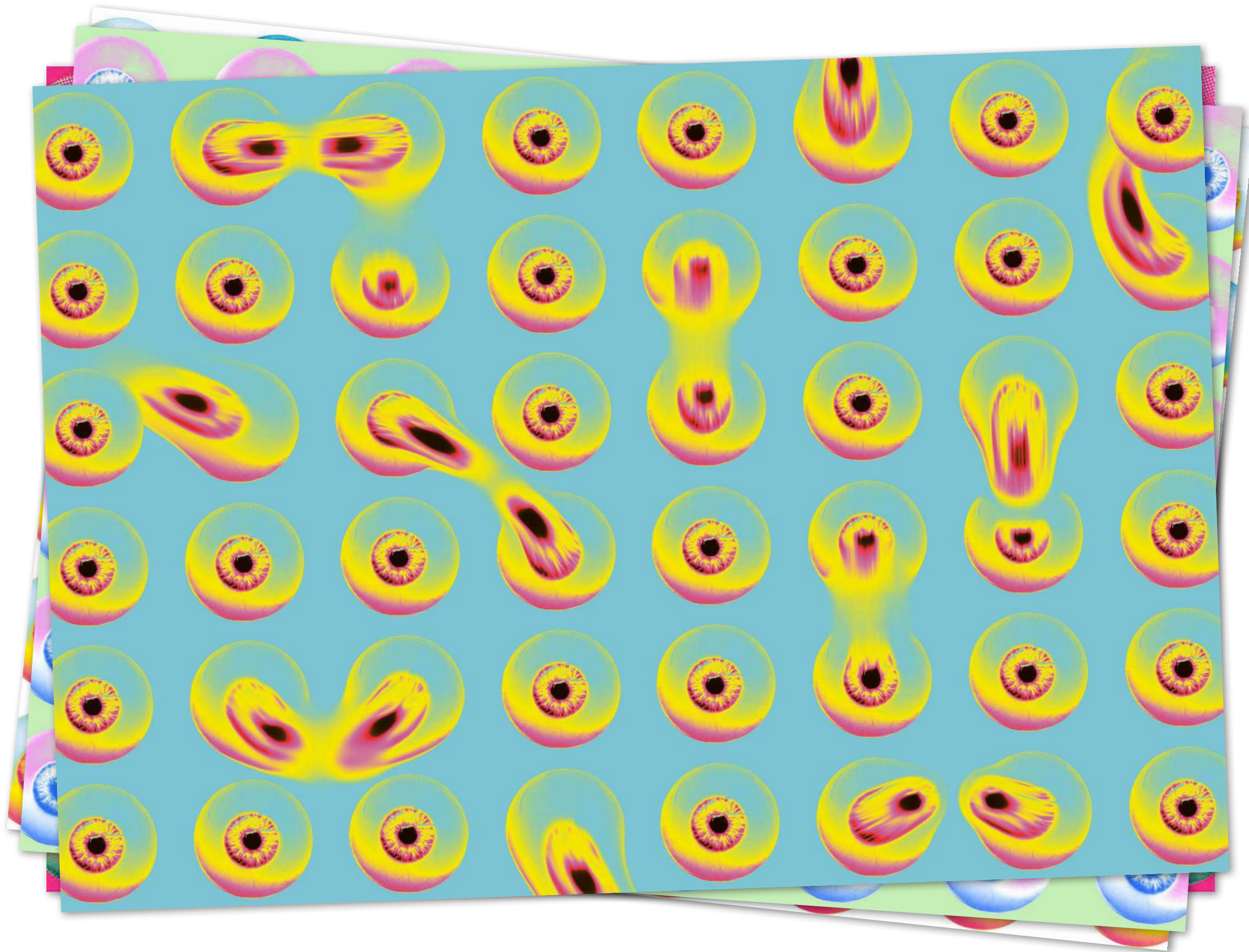

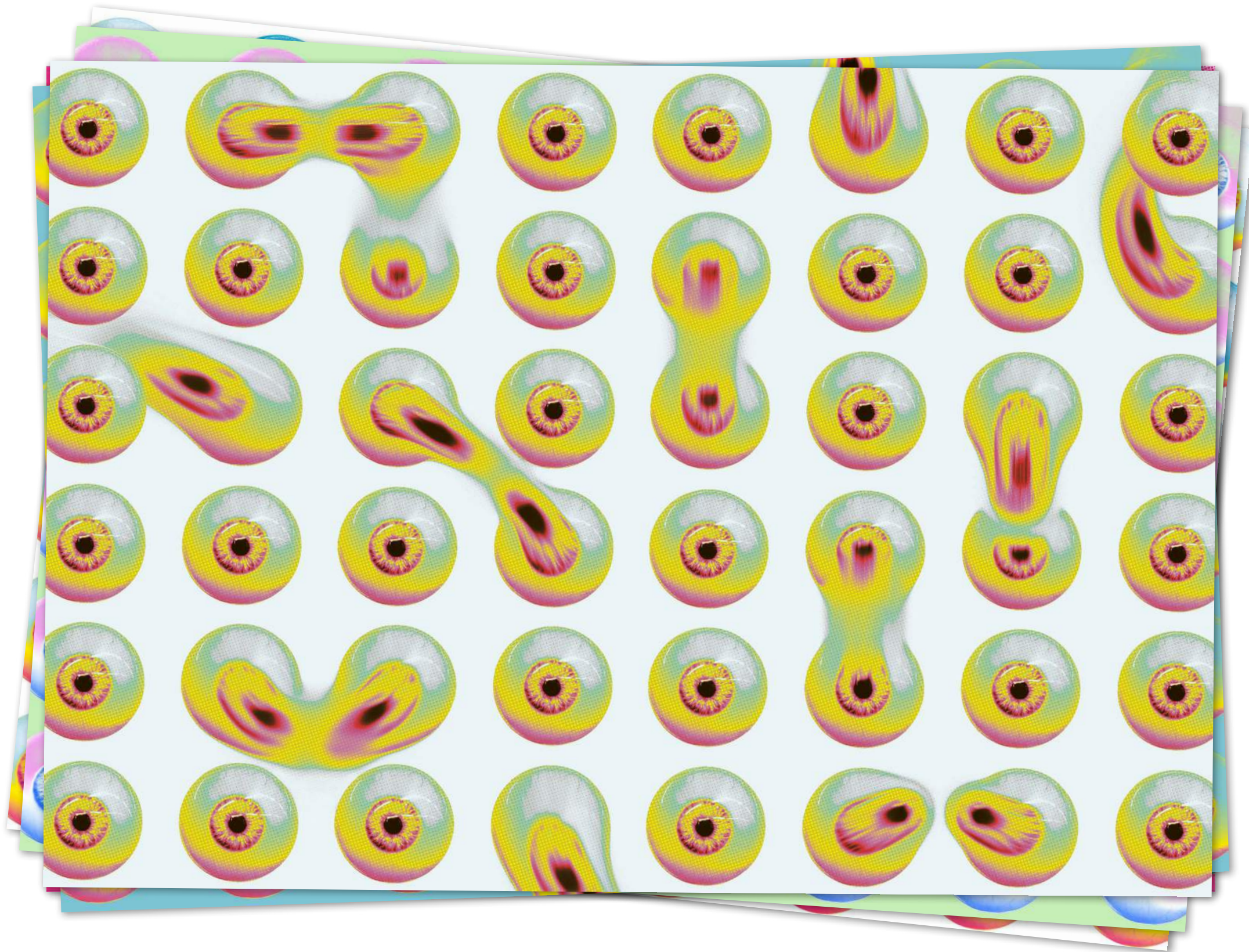

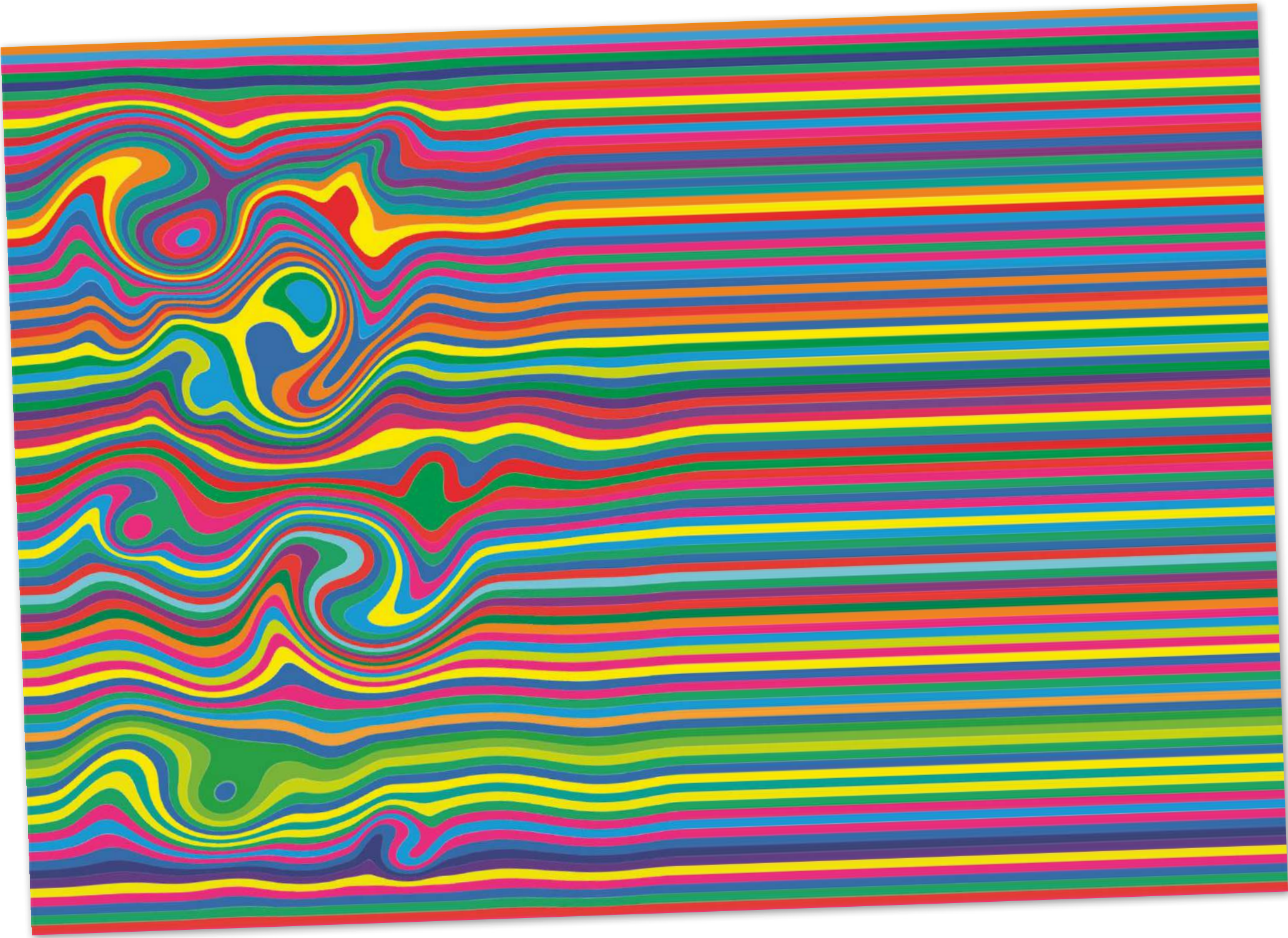





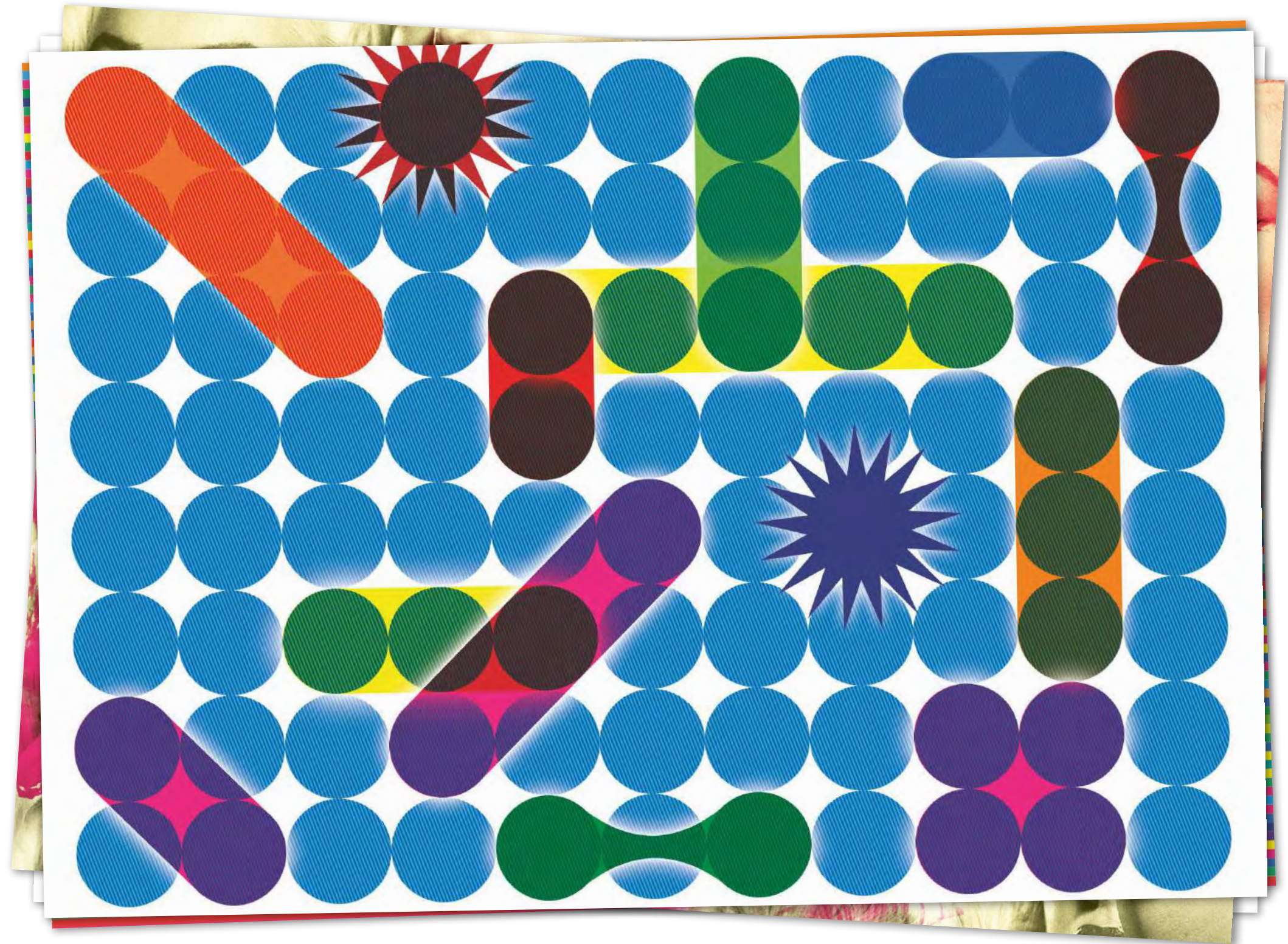

# 05 LE TEMPS *PASSE*



Time constantly passes. For this project I explored different ways of representing motion on paper. How can you illustrate movement on a still piece of paper? I wandered around the city of Lucerne to collect material of people moving–time passing. The booklet guides you through a day in the city of Lucerne where everything is in constant motion.

LECTURERS  
Christoph Fischer  
Martin Infanger  
Philippe Desarzens  
Marianne Halter





Madlen Nitsch  
FG2 2020 ©

**8:35 AM**

*attendant  
le bus*



On attendant le bus et on as  
l'impression d'attendre des  
heures. Je remarque que les  
gens sont un peu sans vie  
en ce moment. L'énergie  
viendra plus tard, je pense.

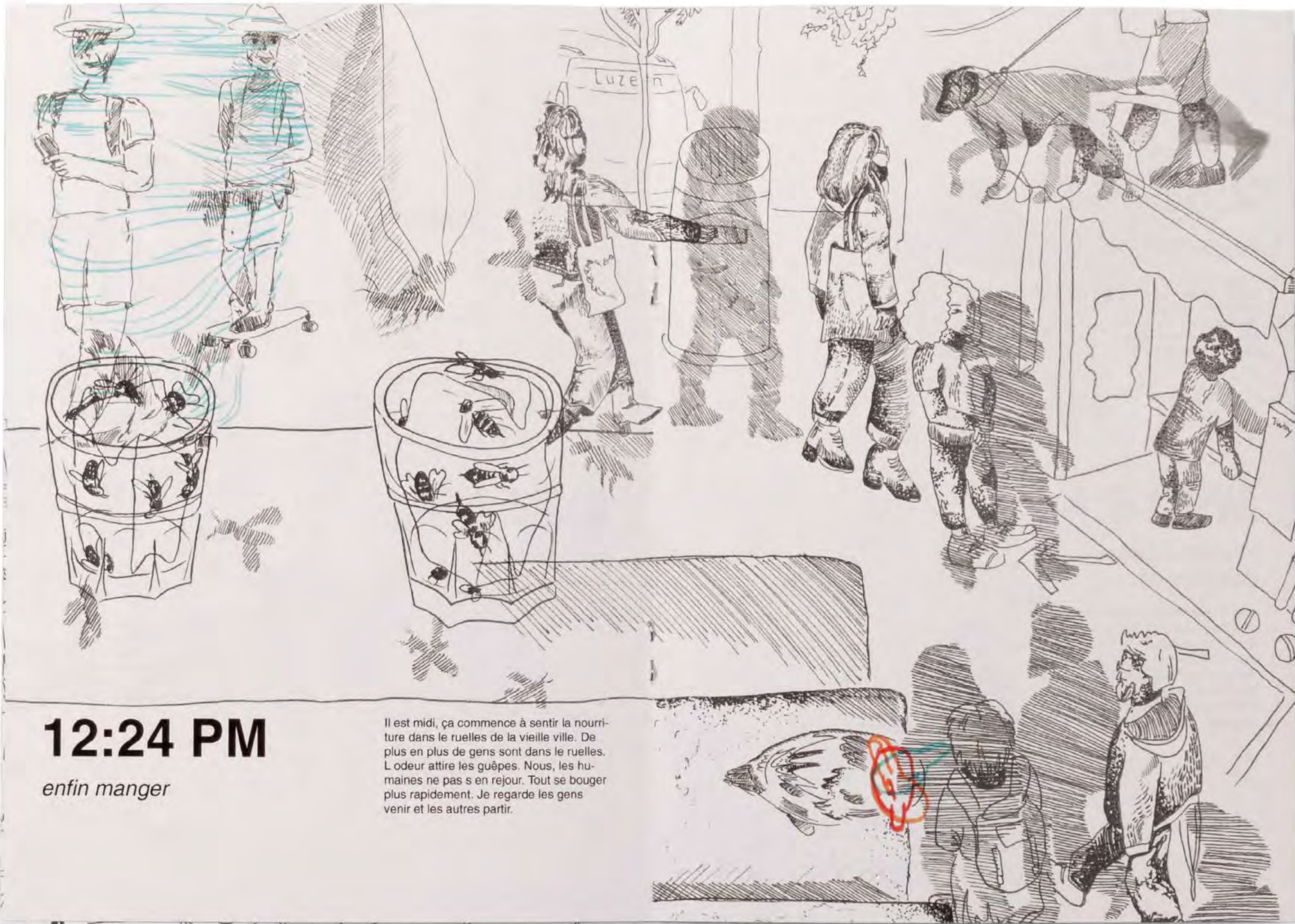

**12:24 PM**

*enfin manger*

Il est midi, ça commence à sentir la nourriture dans le ruelles de la vieille ville. De plus en plus de gens sont dans le ruelles. L'odeur attire les guêpes. Nous, les humaines ne pas s'en rejour. Tout se bouger plus rapidement. Je regarde les gens venir et les autres partir.



## 2:59 PM

*pause de l'après midi*

L'après midi il y a moins de mouvement, mais il y a quand même beaucoup de monde ici. Probablement parce que plus des personnes ont une pause à l'heure actuelle.



## 4:51 PM

*rafraîchissement  
s'il vous plaît*

Il y a du mouvement toute la journée, partout. Il fait chaud. De temps en temps, les gens viennent se rafraîchir au lac avec de l'eau dans leurs paumes. Beaucoup sont fatigués et le mouvement est aussi lentement — le calme avant la tempête.

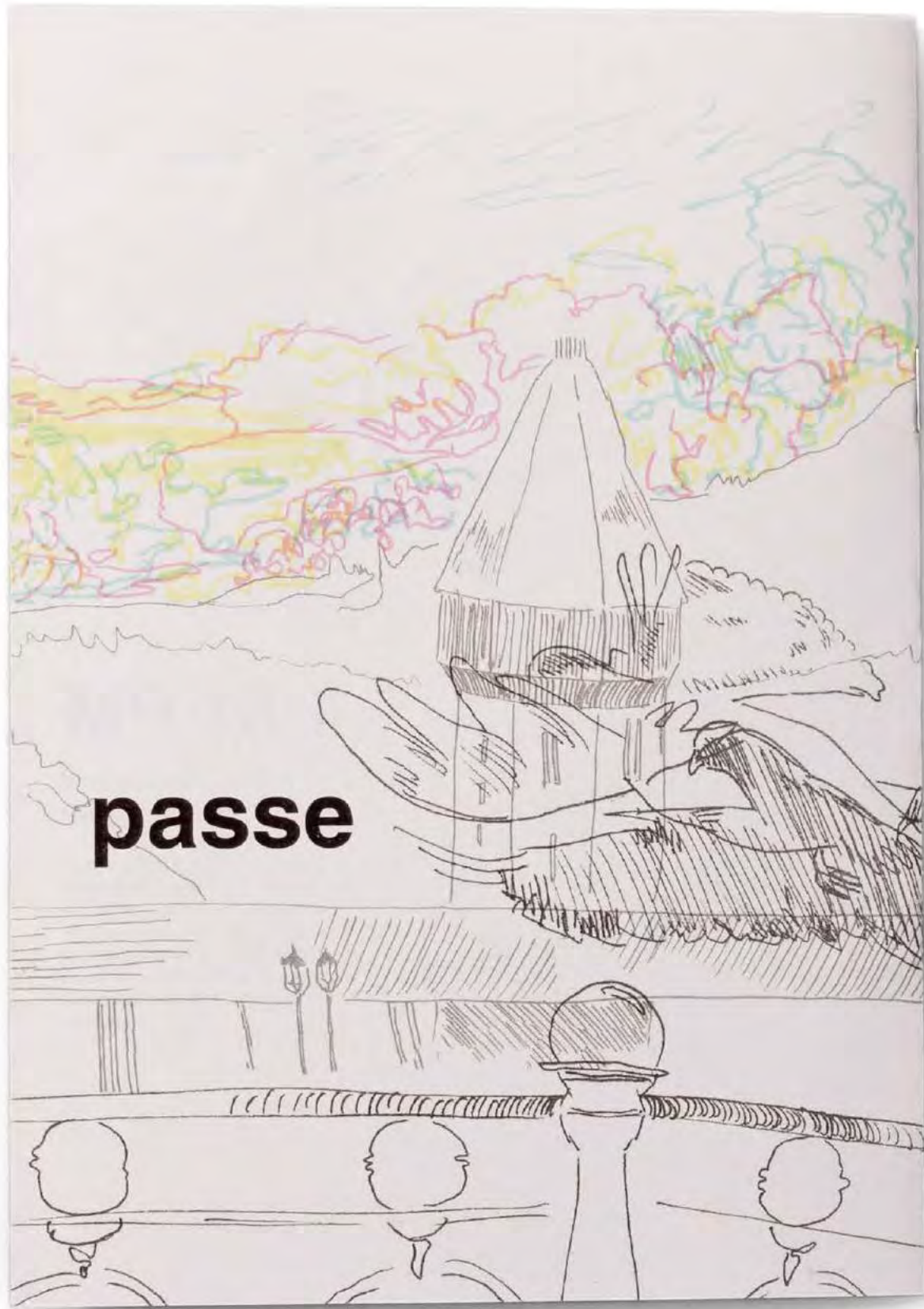

# 06 GOING IN *CONTOURS*



Time constantly passes. For this project I explored different ways of representing motion on paper. How can you illustrate movement on a still piece of paper? I wandered around the city of Lucerne to collect material of people moving–time passing. The booklet guides you through a day in the city of Lucerne where everything is in constant motion.

LECTURER  
Patrina Strähl



# Gino Sarfatti



Entworfen wurde diese glamouröse und auffallende Lampe für Arlecchino im Jahr 1939. Die einzigartige Kronleuchte aus Messing trägt die Modell-Nr. 2003 und wurde in den 1950er Jahren in Italien designed. Diese raumfüllende komplett originale 24-Licht-Sputnik-Deckenleuchte besteht aus röhrenförmigen Messingarmen, die in verschiedene Richtungen laufen, die auf eine Messingstruktur mit Baldachin strahlen. Für um die 24'000 Schweizer Franken kann man dieses Designerstück kaufen.



Gino Sarfatti war ein italienischer Interiorschöpfer und Unternehmer (1912 - 1985). Sarfatti war ein visionärer Designer seiner Zeit vorerst: er verwendete Materialien, die sich erst in späteren Jahren etabliert haben. Einige Stücke Sarfattis wurden in die Sammlung des Museums of Modern Art aufgenommen. Zehn Jahre später kreierte Sarfatti seine Tischleuchte aus Metall und Leder her, die die Qualität so darstellt als wäre sie ein Bausatz. Dieses ungewöhnliche Design machte Gino Sarfatti so einzigartig. Sarfattis Design trübten nicht lange unbemerkt, haben zahlreichen Design Liebhabern, wurde er auch mehrfach ausgezeichnet. Auf der Höhe seines Erfolgs zog er sich zurück, um ein Privilegien abseits der Designwelt zu leben.



# Arne Jacobsen



Die Rede ist von einem der bekanntesten Stühle des dänischen Designers und Architekten Arne Jacobsen. Das Meisterstück ist bequem, stapelbar und fein gebaut. Die Sitzfläche und die Lehne bestehen aus einem einzigen Stück Furniersperholz und hat eine arg schmale Taille. Die Tallenform war schlussendlich namensgebend für den Stuhl. Seine Beine sind aus dünnen Stahlrohren gefertigt worden. Die verwendeten Materialien und seine Bauweise verleiht dem Stuhl ein vergleichsweise geringes Gewicht. Der „Ameisenstuhl“ wurde ab 1952 durch den dänischen Möbelhersteller Fritz Hansen produziert. Heute kriegt man so einen Stuhl ab 400 Schweizer Franken.



Arne Jacobsen (1900 - 1977) gehört zu einer der internationalen bedeutendsten Architekten und Designer des 20. Jahrhunderts. Vor allem ist er dafür bekannt das fast alle seiner Architekturprojekte als Gesamtkonzepte entstanden sind. Er entwarf nicht nur Häuser sondern auch Möbelstücke wie zum Beispiel den Stuhl zu Auherrbecher bis zu jedem Detail der Innenausstattung. Neben vielen zahlreichen architektonischen Werken, die in ganz Skandinavien zu sehen sind, befinden sich seine Werke heute in zahlreichen internationalen Sammlungen, darunter im Museum of Modern Art in New York, im Design Museum in London und im San Francisco Museum of Modern Art.



# George Nelson



Den „Kokosnuss“ Stuhl verglich George Nelson selbst mit einer in acht Teile aufgeschnittenen Kokosnuss. Nur die Farben sind konträr, außen weiß und innen das Einseitige, bequeme Polster mit hochwertigen Leder- oder Stoffbezügen ist in verschiedenen Farben ist. Der Coconut Chair wurde von George Nelson Mitte der 1950er Jahre designed und vermarktet. Das Untergestell aus verchromtem Stahlrohr stützt die gepolsterte Sitzschale. Der Designklassiker Coconut Chair wird heute von Vitra vertrieben und sorgt im Raum für eine Prise Mid-Century-Modern. Kaufen kann man den einzigartigen Sessel heute ab 3'600 Franken.



George Nelson (1908 - 1986) war ein US-amerikanischer Designer, Architekt und Journalist. Er studierte an der berühmten Yale Universität und später an der American Academy in Rom. Er ist einer der bekanntesten amerikanischen Designtheoretiker. Kein Designer hat so klug über Design gesprochen und über Design geschrieben wie George Nelson - (Volltextauszug). Seine Entwürfe prägen das Sortiment des Herstellers Vitra über Jahrzehnte hinweg. Aus seiner Feder stammen Designklassiker wie die Ball Chair und der Coconut Chair von Vitra. Seine unvergesslichen und abstrakten Designs bekamen unzählige Auszeichnungen und Preise. Heute zählen der Coconut Chair, das Marshmallow Sofa und die Wand- und Tischleuchte Design zu den bekanntesten Entwürfen Nelsons.



# 07 PEACE IN *CHAOS*



Chaos, noise, and stress. That's what the first page of this paper displays. The many little cut-outs merging into one bigger picture. In this project I primarily collected photographic material wandering around in the city of Lucerne with my analogue camera. Shortly I settle on showing snippets of beautiful things such as the glittering water in comparison to a hideous graffiti. While going through the paper the chaos continuously dissolves. On the last page the tumult has dissolved.

LECTURERS  
Melchior Imboden  
Martin Woodtli

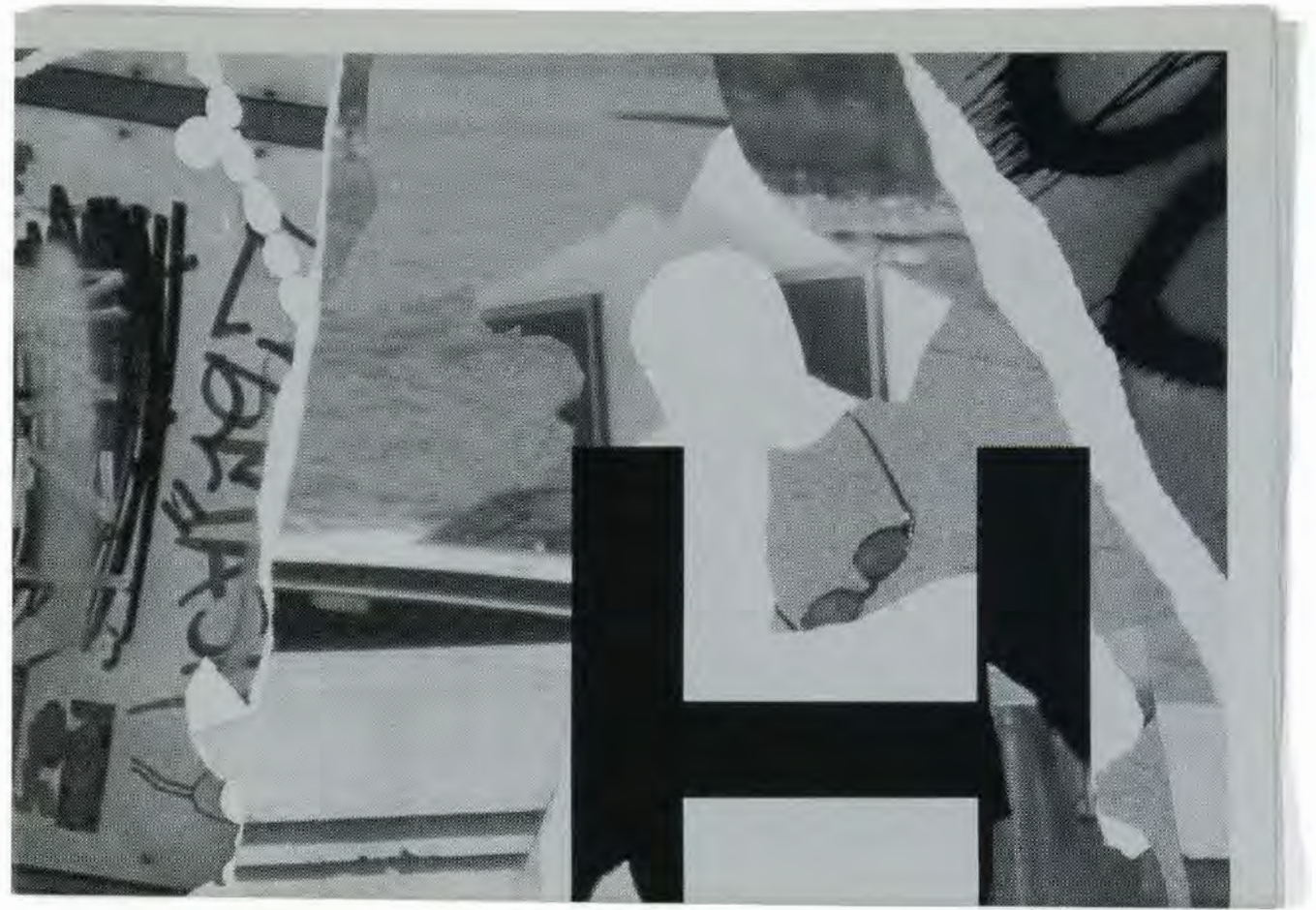

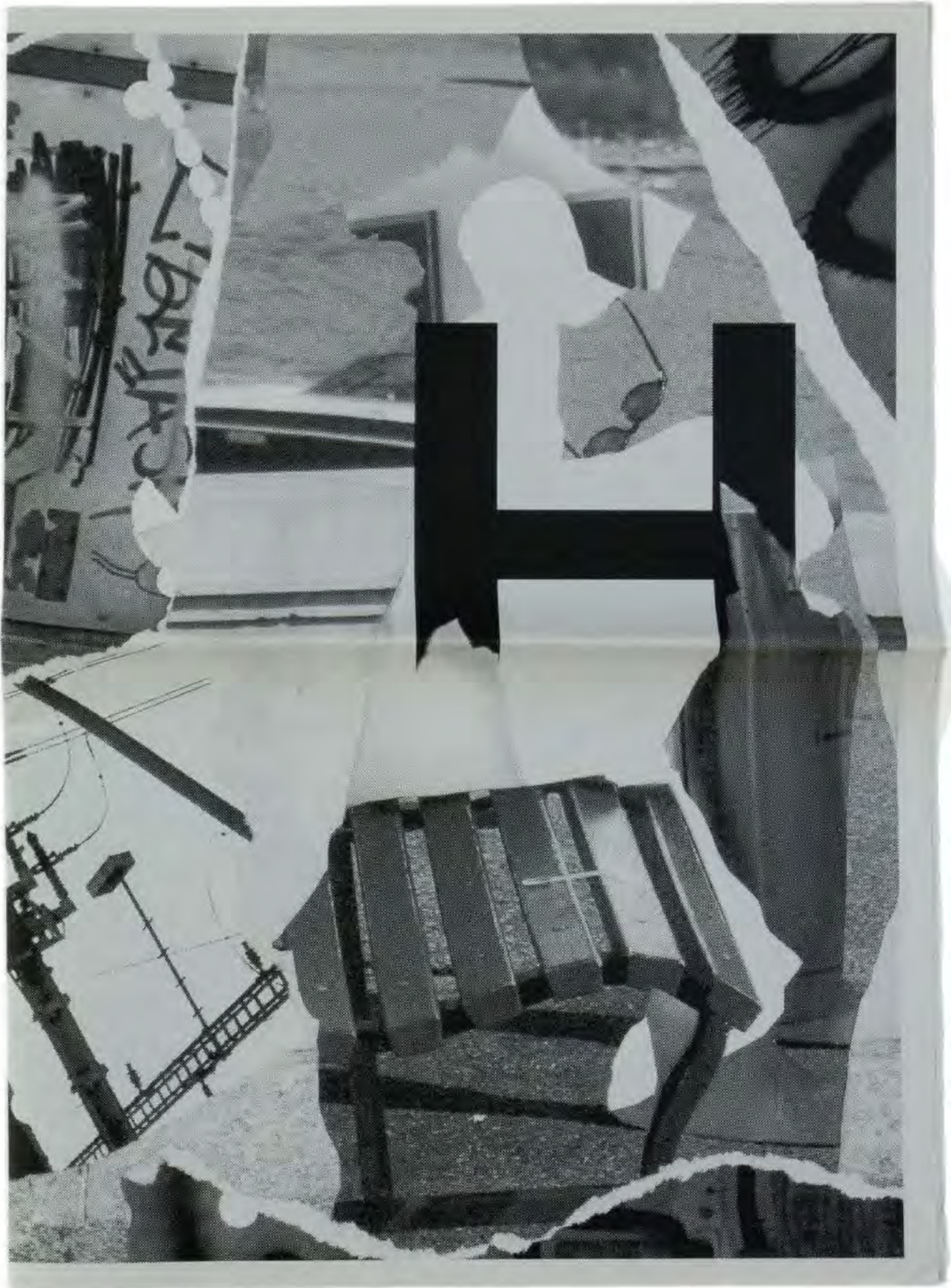





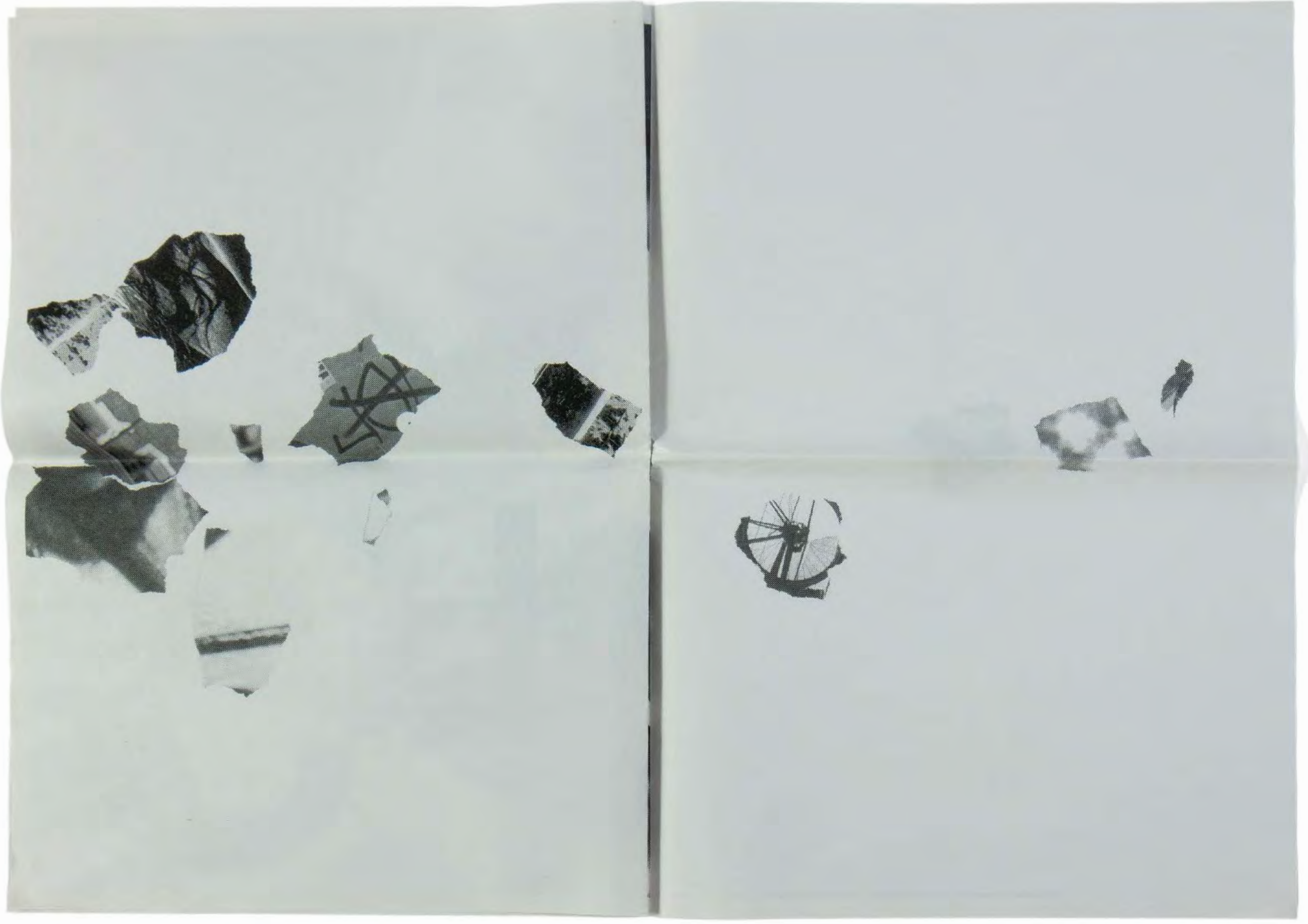



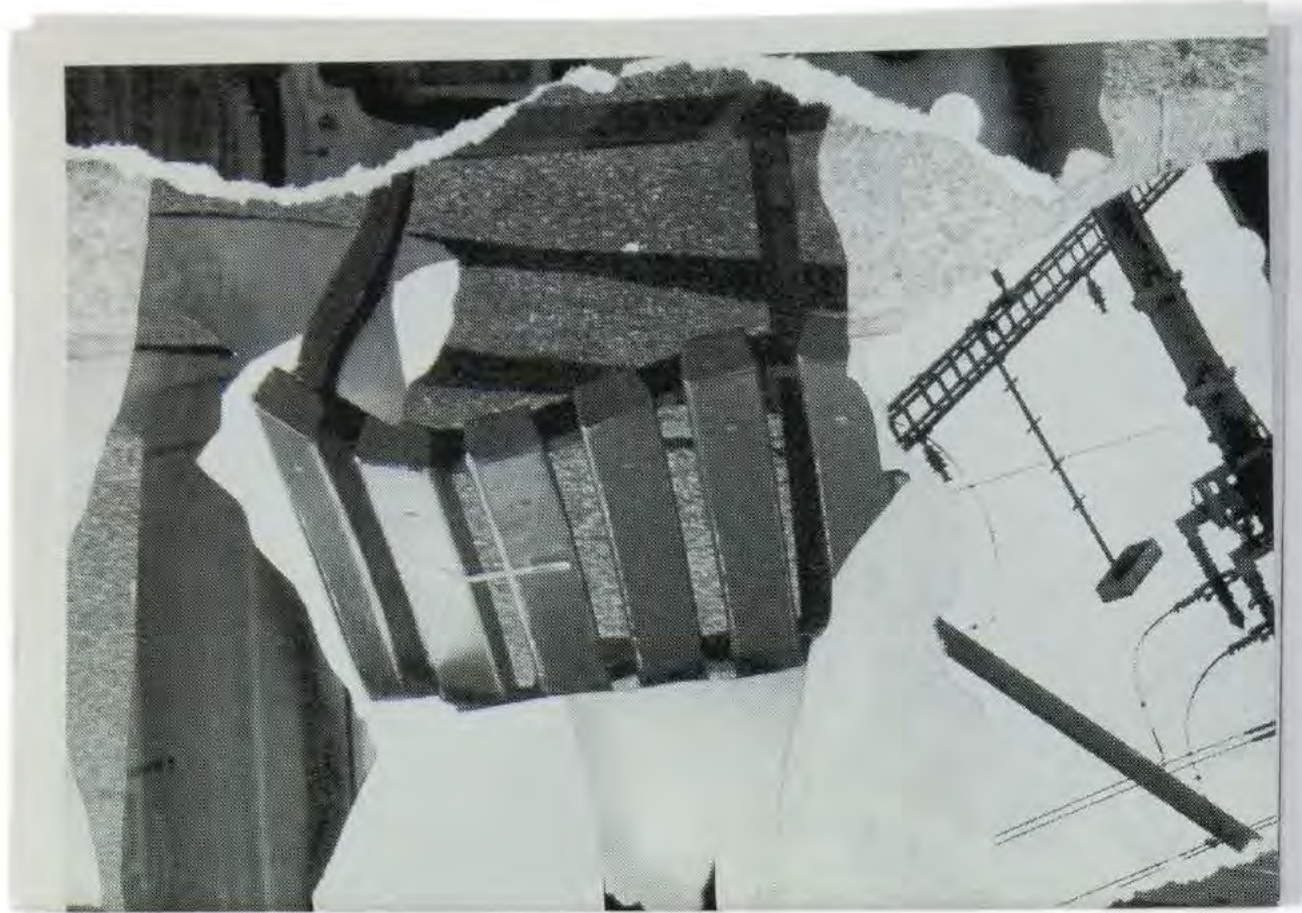

# 08 ON THE GO



Over the course of being in this school I discovered an interest in photography. When having the time, I like going to a busy city and capturing moments of people, architecture and so on. Here are some of my takes on photography.









Large stylized graffiti letters, possibly spelling 'MATTING' or similar, covering the windows of the upper floor.

MATTING CULTURA ♀CLC

TURN-UP  
EIND TRÄNE,  
MER TANZED  
UF SCHÄTTE

NK!  
NK!  
M

Stit.

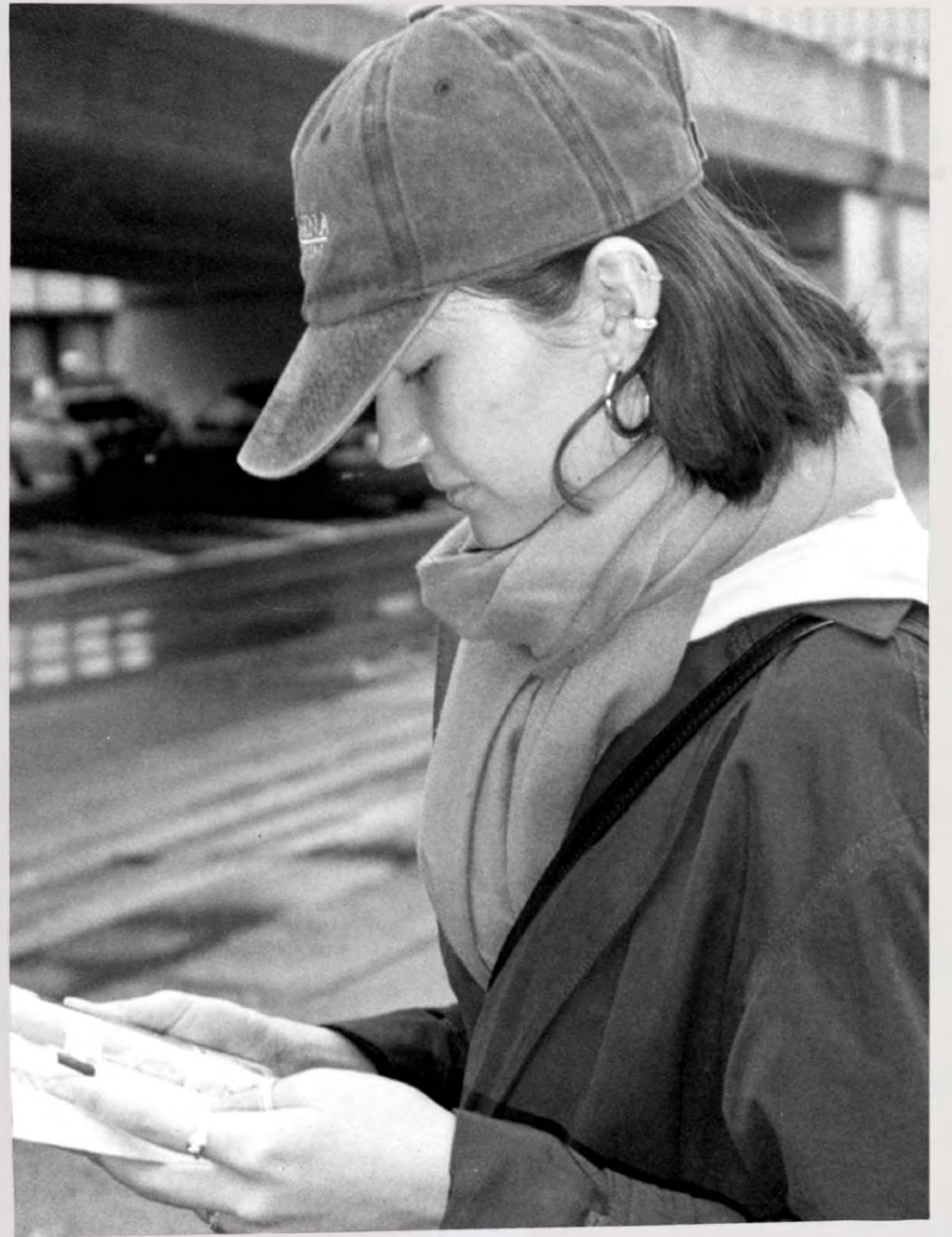



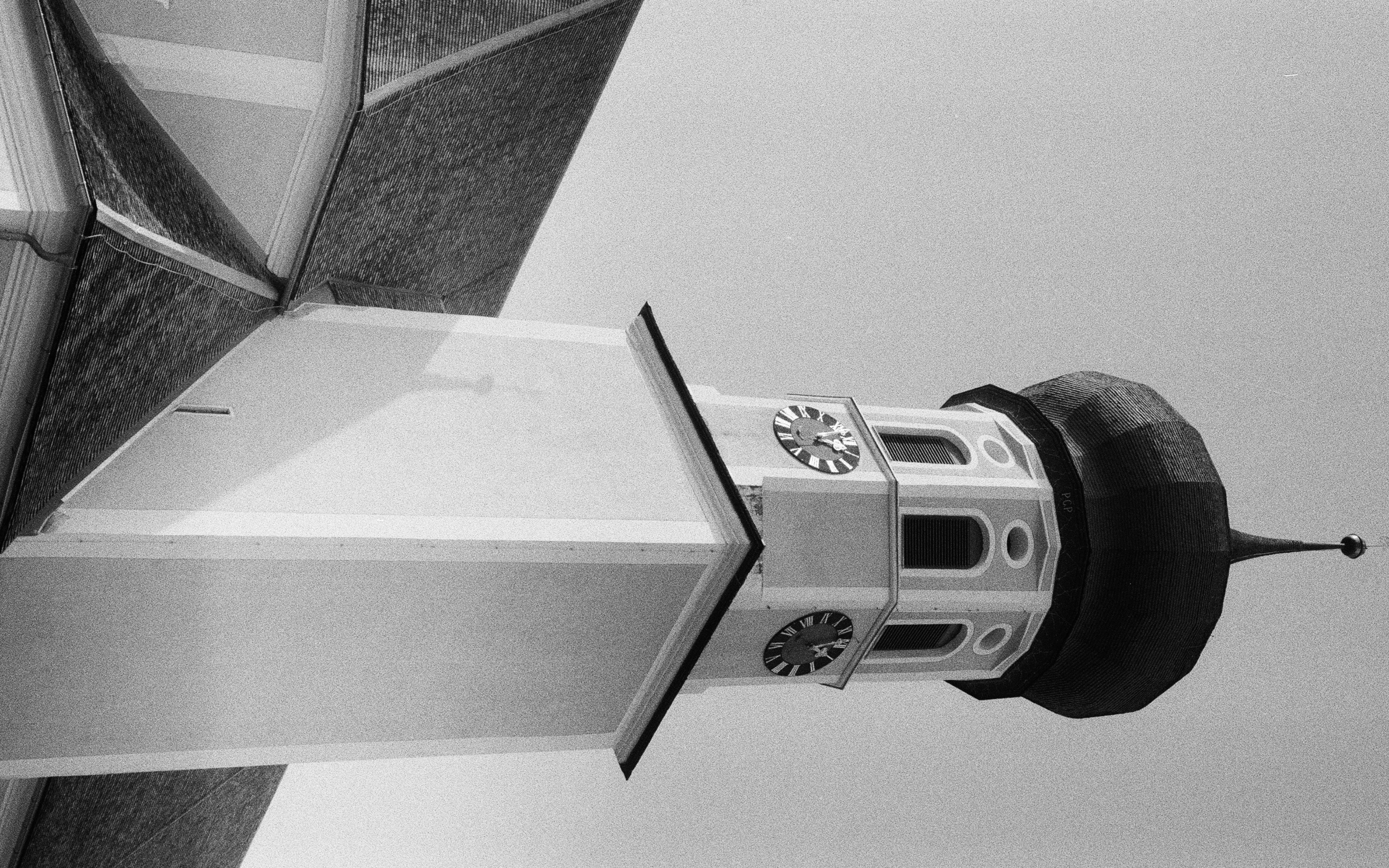

# 09 EMOTIONAL *EYES*



Everyone played by the same rules—but each student ended up with different outcomes. In this short project in the middle of the pandemic we used the tool of communicating through Teams. The only instruction given was to make the instructions short and understandable. Making it understandable for the class comrades in the short time window open—over chat. After gathering all the material needed, we had to turn that into one final product.

I had the idea of making an animation which included everyone drawing eyes for me and then realizing this into an animation—and later into a thumb cinema. Everyone had to draw eyes for me in four states. Closed, semi closed, half open and open. Not to forget each person was given an emotion in which they drew the eye in. The final product is an animation of an eye opening and closing again. I additionally turned the animation into the handy form of a thumb theatre book. If your eyes are not closed yet—have a look!

LECTURERS  
Felix Pfäffli  
Tobias Klausner

emotionale Augen





*Müdes Auge*

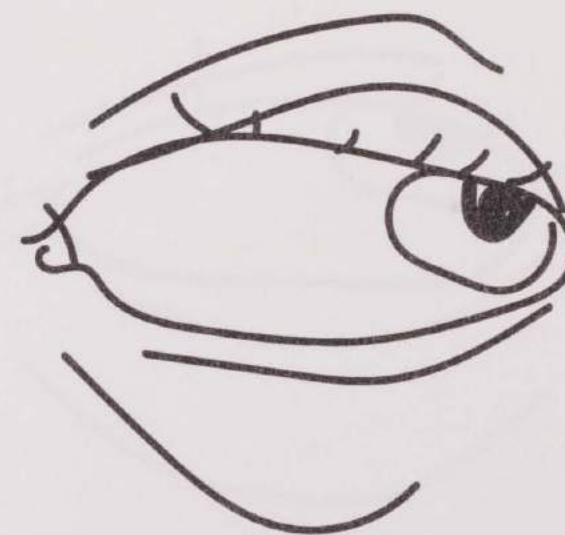

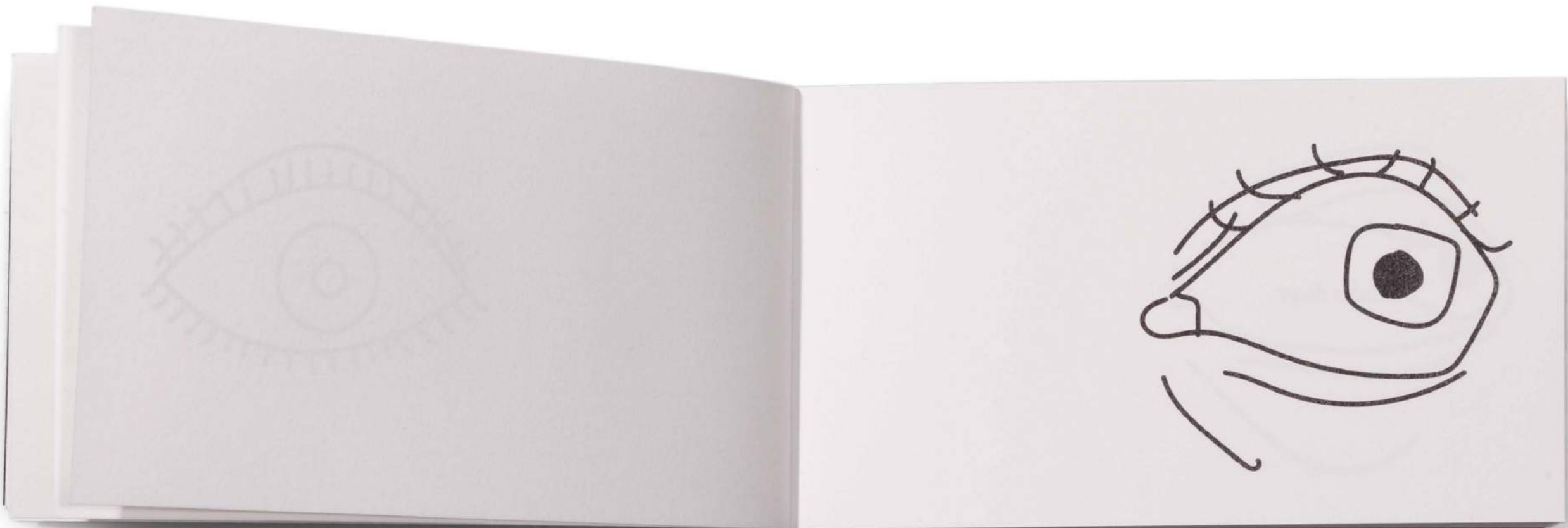

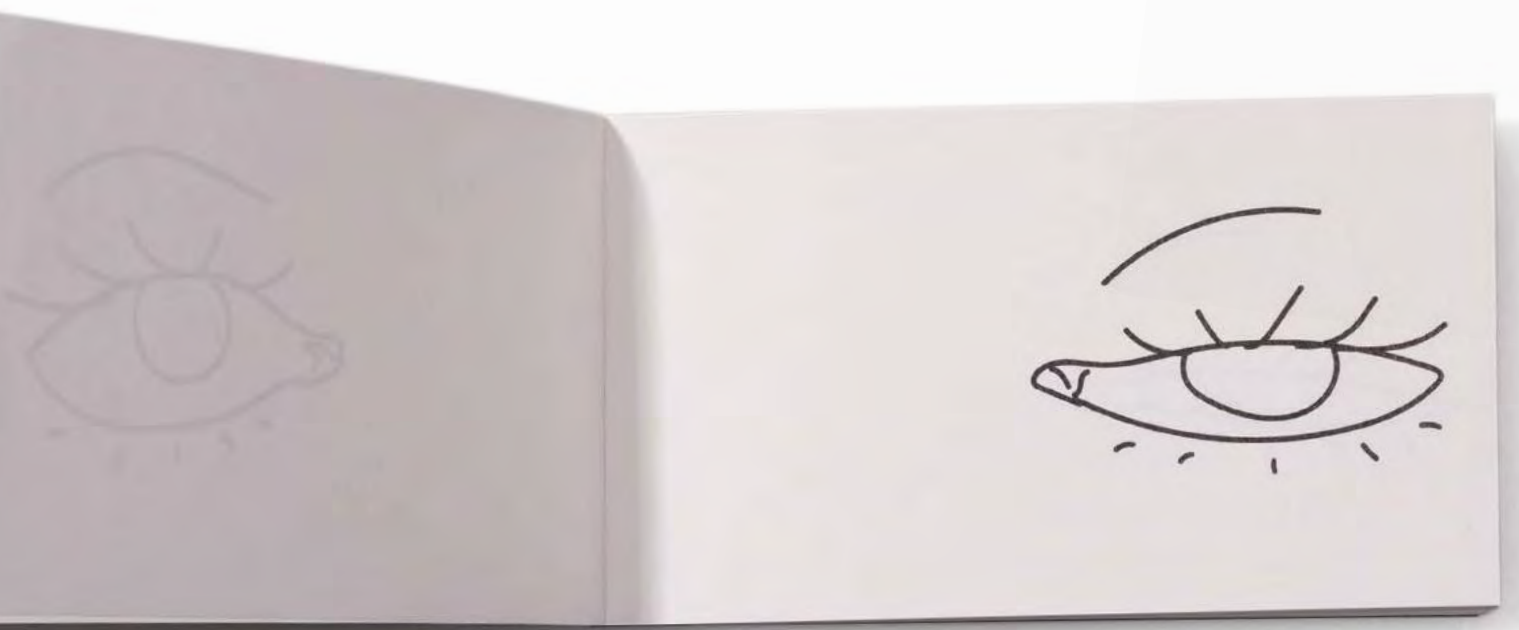

# 10 THE DISSASSEMBLED *MOUSE*

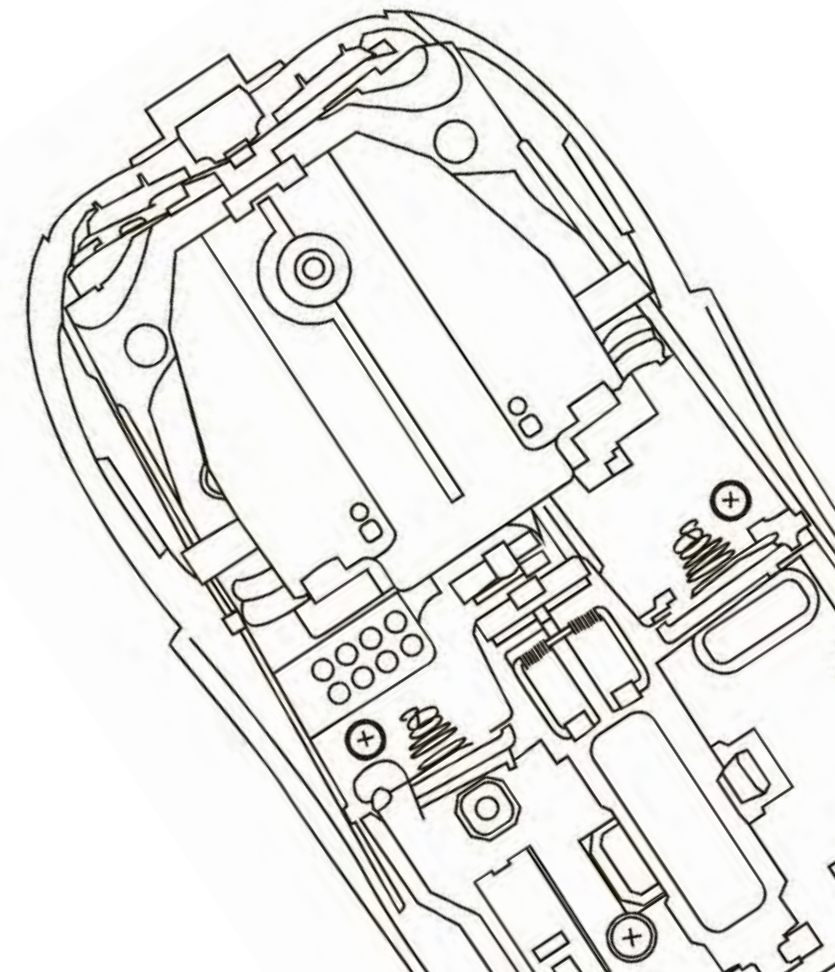

Making a font from dismantling a digital mouse. That was the task. I started by illustrating the outer body and proceeded to disassembling the mouse. After breaking up the mouse into its inner parts and several complex constructions I was able to illustrate it. That is not the end, the following task was creating a font. Not just any font, but we got assigned a song—mine being “Transmission” by Joy Division—for which we created a fitting font. The process was very interesting to me and introduced me into the world of illustrating and the program “Glyphs”.

LECTURERS  
Mauro Paolozzi  
Martin Woodtli

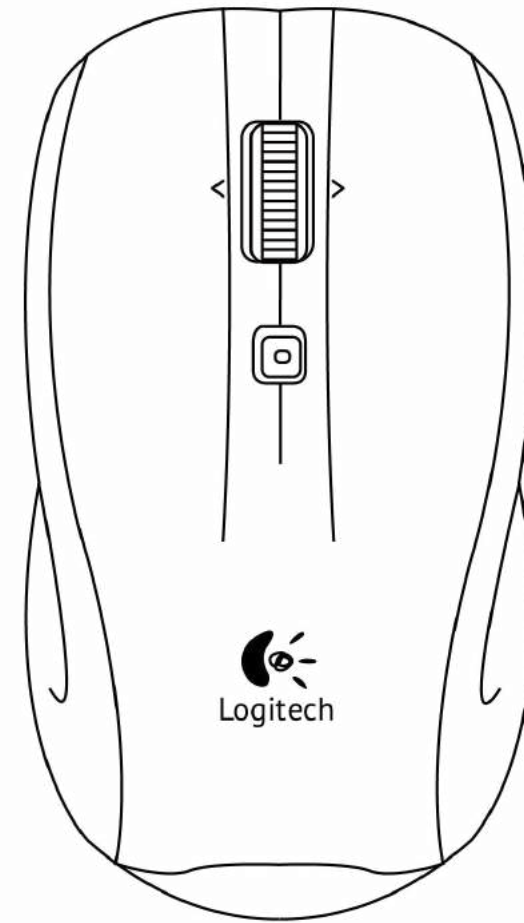
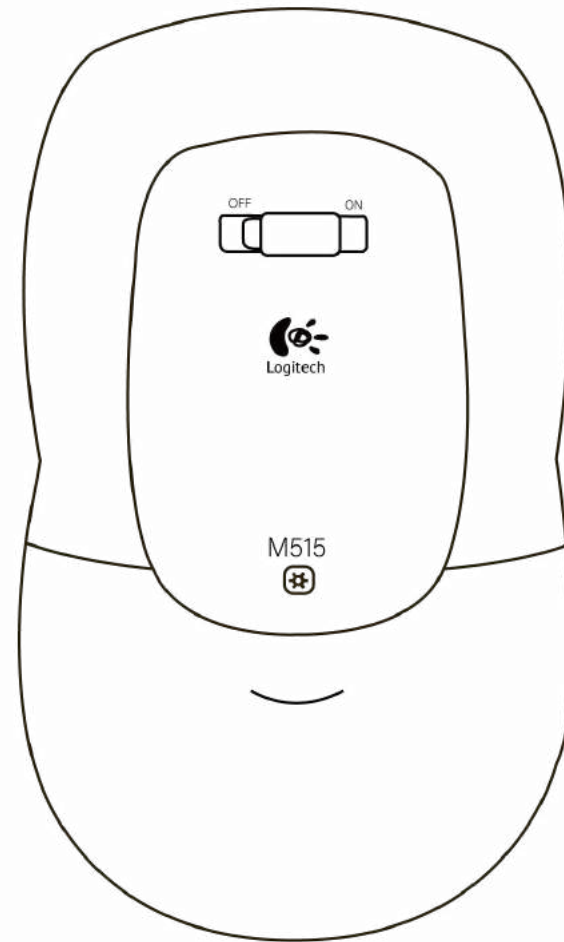
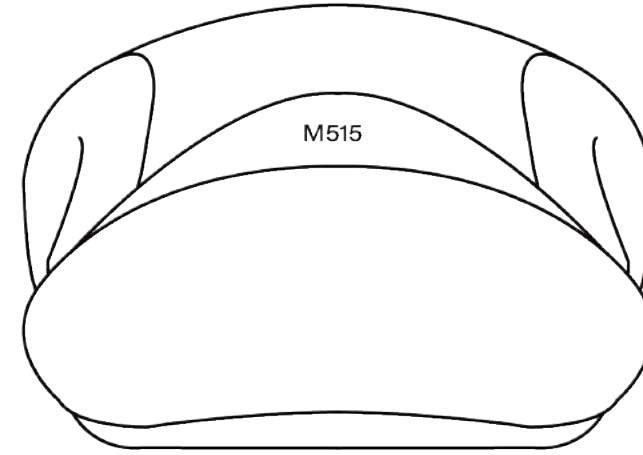
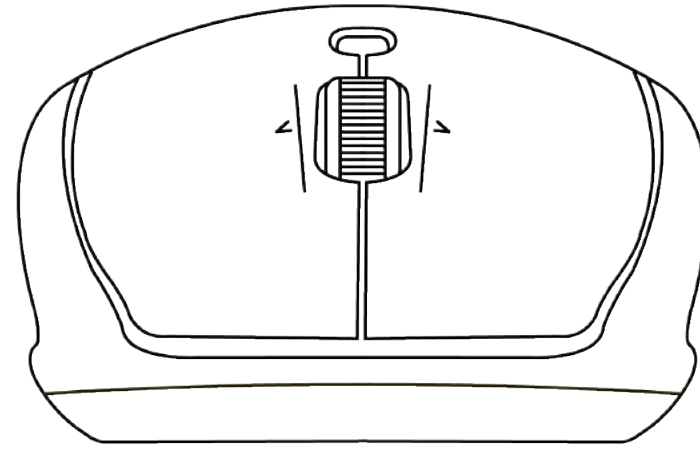

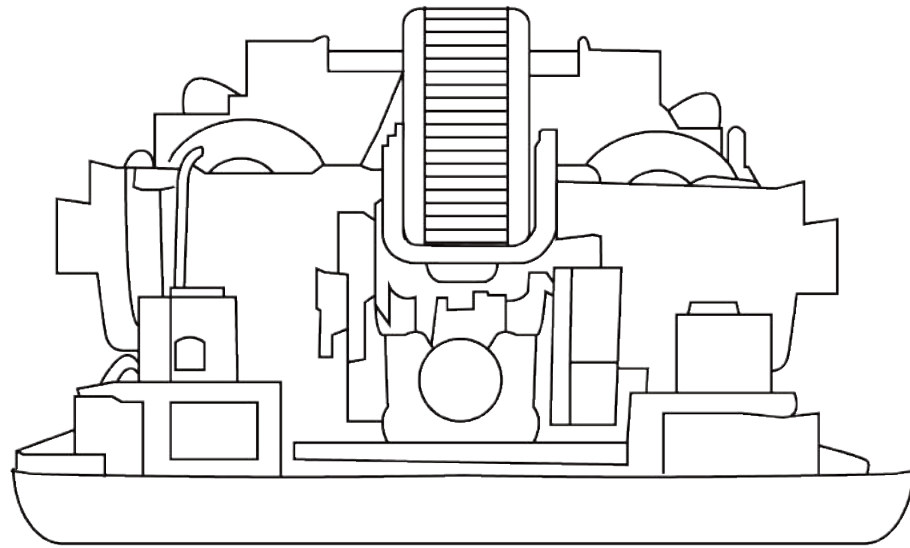
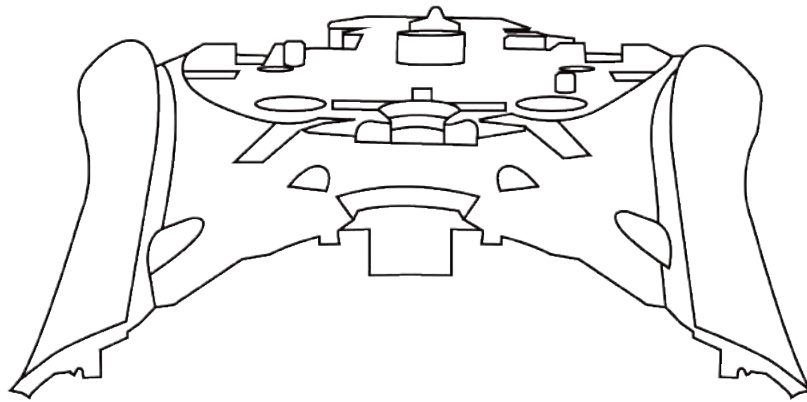
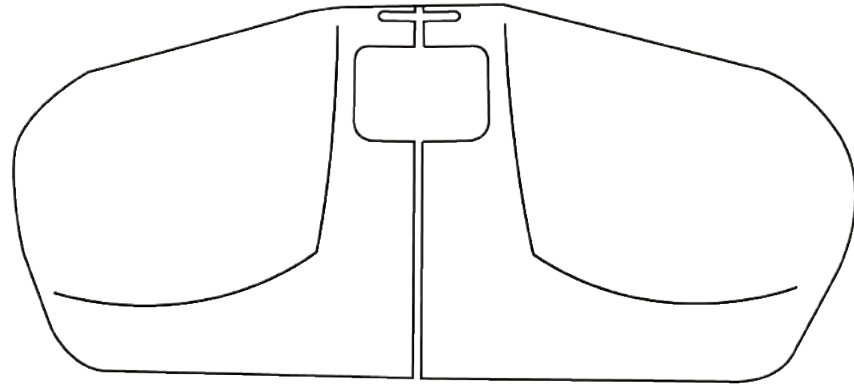

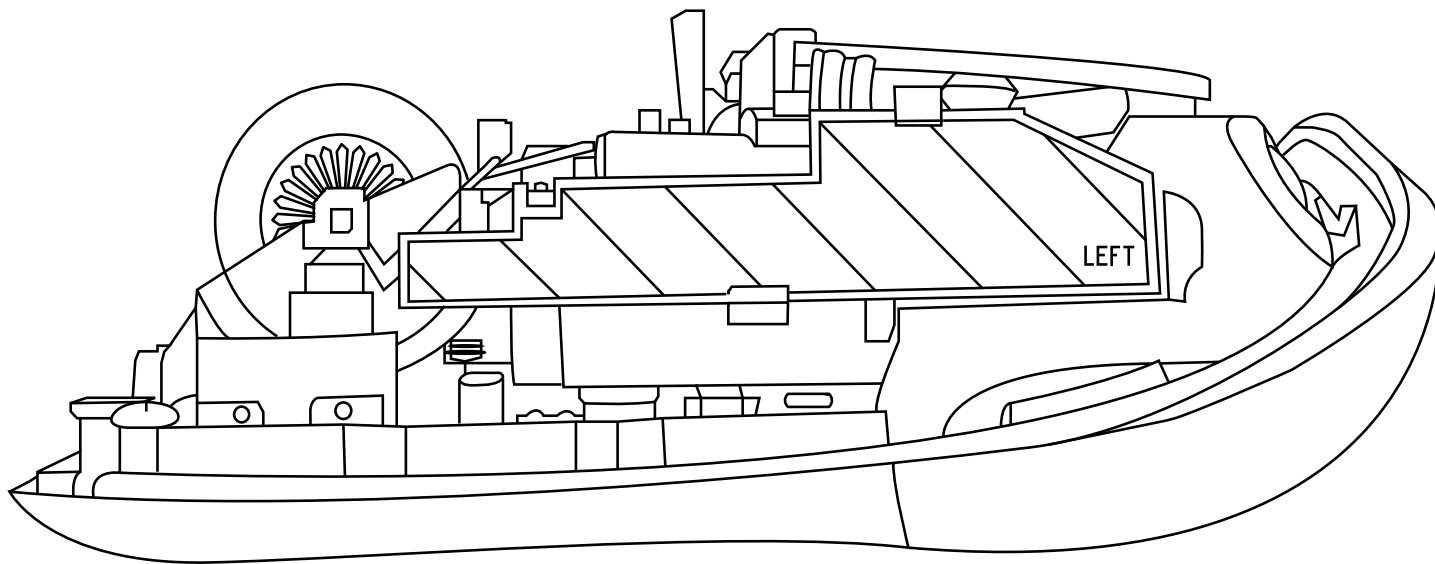
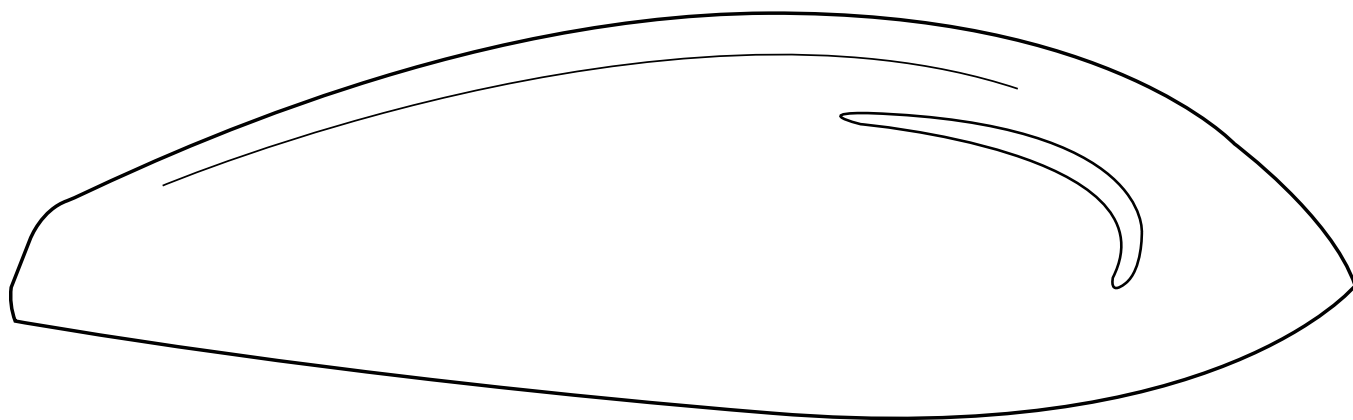
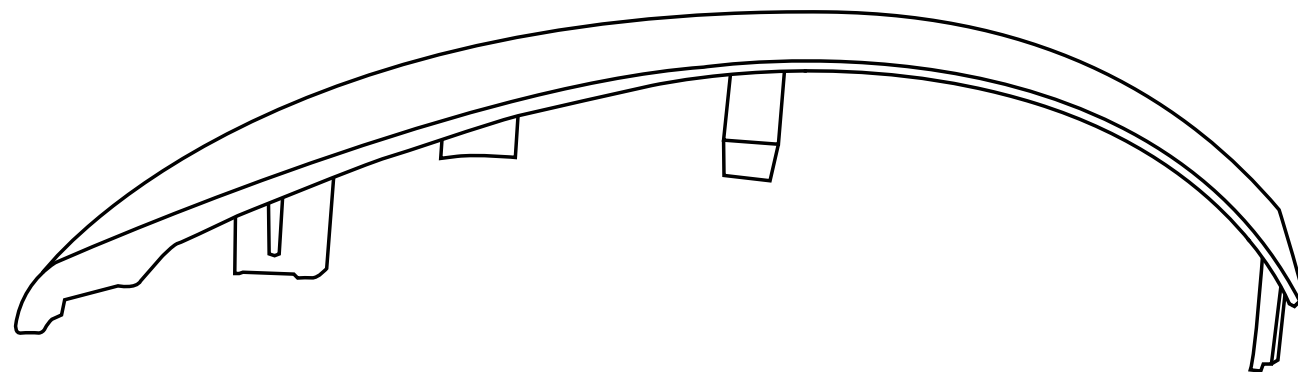

Damen 36pt/100pt

Schindler © Carl Moser AG FG Luzern

# Type Specimen FG Luzern

Wasserfall 120pt, 90pt, 72pt, 60pt, 48pt, 36pt, 24pt, 18pt

Der Wasserfall  
Der Wasserfall  
Der Wasserfall  
Der Wasserfall  
Der Wasserfall  
Der Wasserfall  
Der Wasserfall

A B C D E F G H I J K L M N

O P Q R S T U V W X Y Z

a b c d e f g h i j k l m n

o p q r s t u v w x y z

? ! . , - ; :

JOY DIVISION  
TRANSMISSION

# II MUSIC IN *COLOURS*



What do we see when we hear music? For the Hochschule Luzerns annual “Masterabschlusskonzerte” I visualized what music looks like to me. Music is the most diverse thing there is. There are million different songs and each sounds different from the other. So in my poster variations I created different objects in various colours to portray the huge individuality and diversity in music.

LECTURERS  
Martin Infanger  
Felix Pfäffli  
Martin Woodtli

Lucerne University of Applied Sciences and Arts

**HOCHSCHULE  
LUZERN**

Musik  
FH Zentralschweiz



[helu.ch/masterkonzerte](http://helu.ch/masterkonzerte)

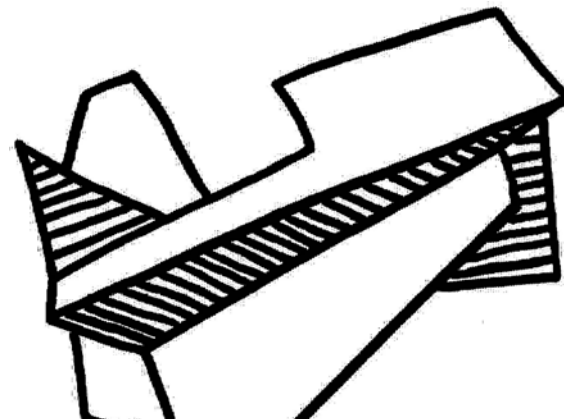
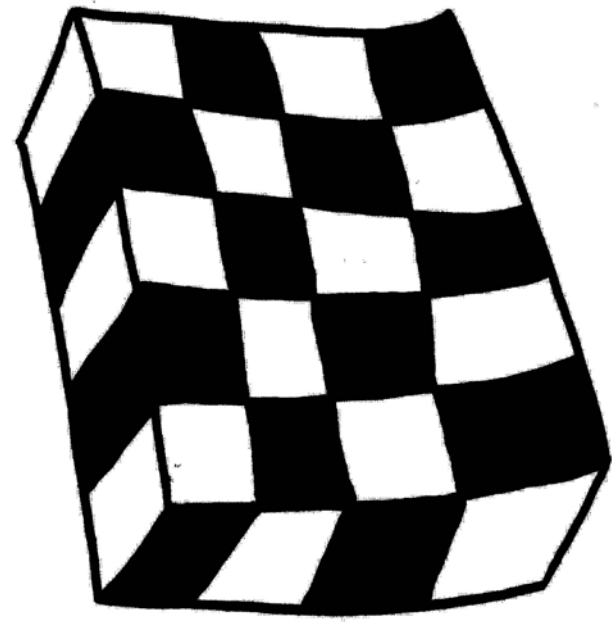
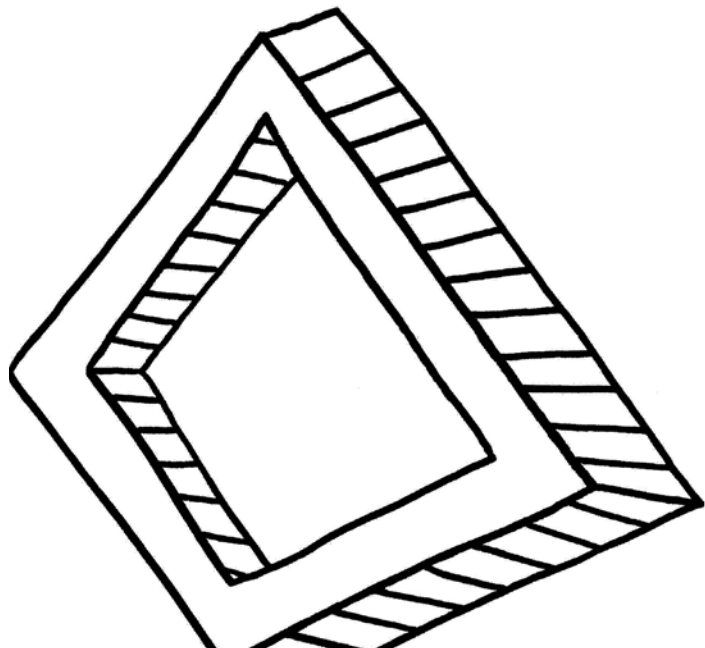
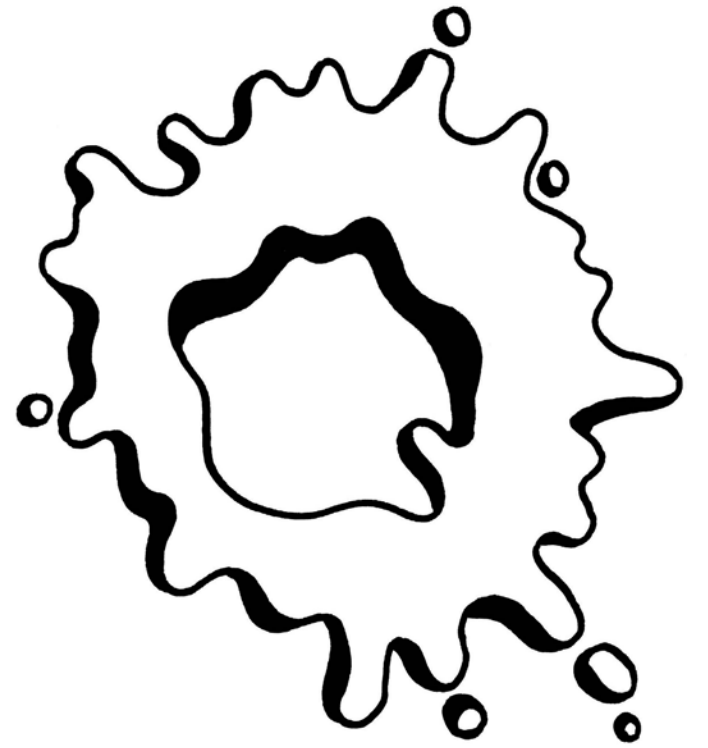
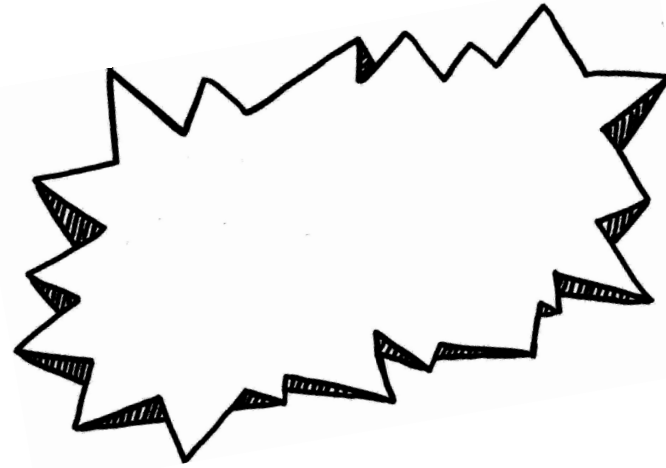
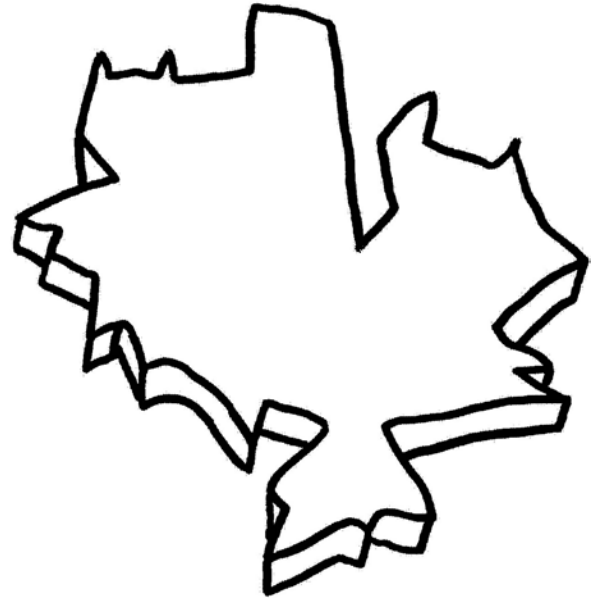
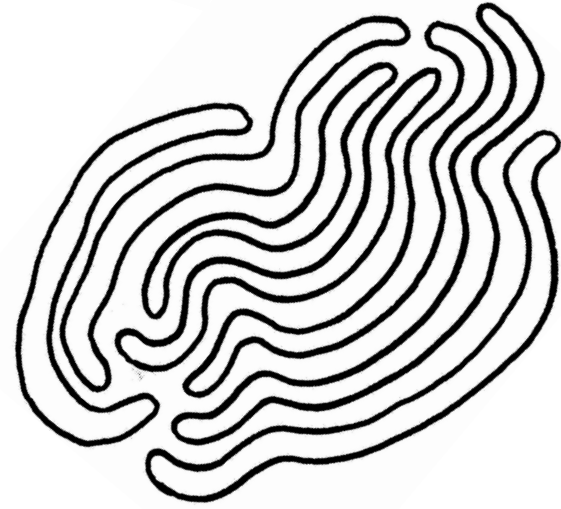
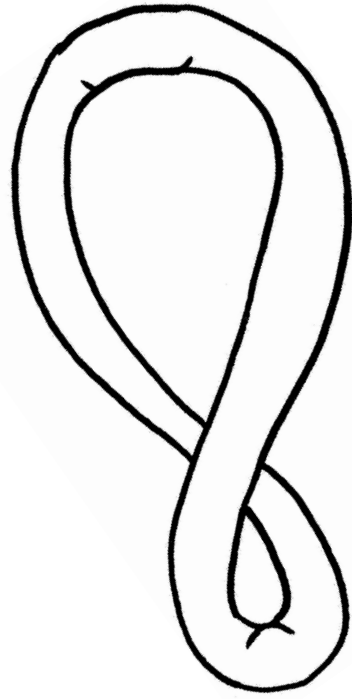
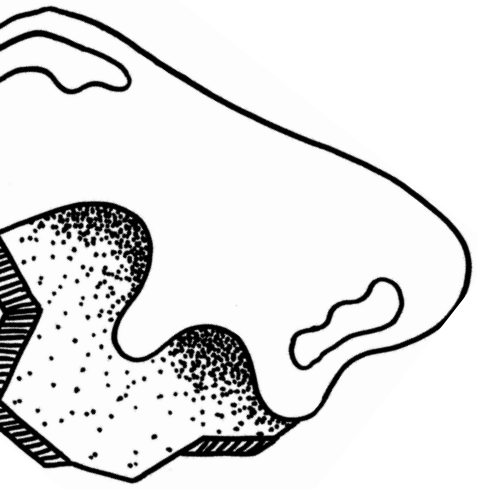
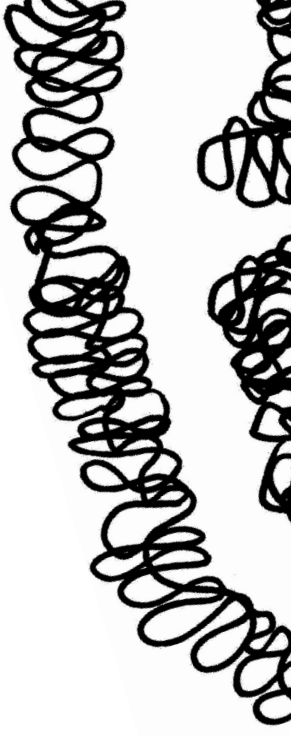
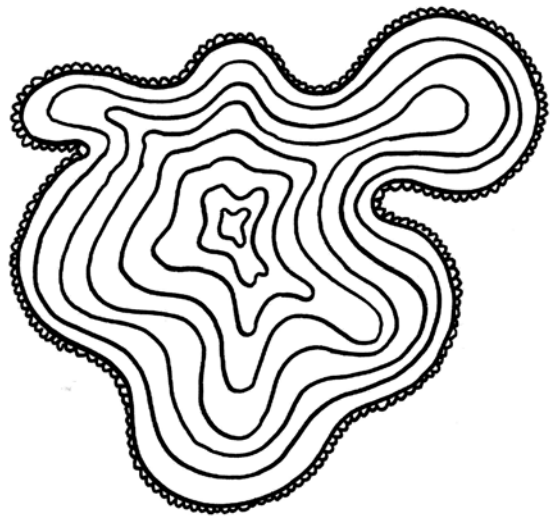



# 12 ABOUT *ME*

Hey! I'm Madlen Nitsch, a 20-year-old graphic designer straight outta Switzerland, and I've just wrapped up my training at the Fachklasse Grafik in Lucerne. My inspiration is a wild mix – the bustle of busy cities, the digital buzz of the internet, movie magic, and the lovely people I cross paths with. Dive into my world, where my passion lies in the interplay of colours, the dance of shapes, and the wide spectrum of design.

I revel in both the digital and analogue realms, from crafting an analogue film to sketching by hand. Inspiration fuels my exploration of diverse directions in design. I have learned that communicating ideas visually and working with typography, photography and illustrations is what my passion is. I am always open for new experiences, developments, techniques, improvements and am constantly being inspired to create unique work and am eager to gather more knowledge and venture further into graphic design!

*LANGUAGE SKILLS*

German – Native  
Russian – Very good  
English – Advanced C1  
French – Good B1

*SOFTWARE SKILLS*

InDesign – Very good  
Photoshop – Good  
Illustrator – Very good  
AdobeXD – Good  
After Effects – Basics  
Premiere Pro – Good

*CONTACT ME!*

madlennitschh@outlook.com  
079 822 53 09

*BACK TO START*

» [CLICK HERE FOR \*MORE\*](#)